

PHASE-SPACE RECONSTRUCTION AND APPROXIMATING RELATIVE DEGREE FROM INPUT-OUTPUT TIME SERIES DATA

David M. Walker and Nicholas B. Tufillaro

April 1998

1 INTRODUCTION

In this letter we attempt to calculate values of important quantities in nonlinear control theory from input-output time series data. A fundamental concept in nonlinear control theory is the notion of relative degree. The text by Isidori (Nonlinear Control Systems, 3rd Edition, Springer) is a good introduction to “state-of-the-art” nonlinear control theory.

The nonlinear single input – single output (SISO) system

$$\begin{aligned}\dot{x} &= f(x) + g(x)u \\ y &= h(x)\end{aligned}$$

has relative degree r at a point x_0 if

- (i) $L_g L_f^{k-1} = 0$ for all x in a neighbourhood of x_0 and all $k < r - 1$
- (ii) $L_g L_f^{r-1} \neq 0$.

($L_a b$ is the Lie derivative of the vector field b along the vector field a .)

The relative degree is the amount of times the output function must be differentiated before the input explicitly appears. (This must also be related to the number of past outputs required before the input affects the output.)

The relative degree is important since it “induces” a coordinate transformation which converts the SISO system into a so-called normal form. The normal form is easier to analyse than the original representation. In addition the normal form can be used to separate the internal (or zero) dynamics from the external dynamics.

An additional property of the relative degree is that for a given output function the relative degree is invariant under coordinate transformations.

For linear systems

$$\begin{aligned}\dot{x} &= Ax + Bu \\ y &= Cx\end{aligned}$$

the relative degree is such that

- (i) $CA^k B = 0, k < r - 1$
- (ii) $CA^{r-1} B \neq 0$.

2 APPROXIMATING RELATIVE DEGREE

The relative degree is an important concept in the theory of SISO systems. We would like to design a diagnostic which can estimate relative degree from input-output data. An approach which immediately comes to mind is the following:

Given input-output data $u(t)$ and $y(t)$ we construct an extended phase space of vectors

$$\begin{aligned}z(t) &= (x(t), u(t)) \\ &= (y(t), y(t-s), \dots, y(t-(d-1)s), u(t)).\end{aligned}$$

For $z = (x, u)$ we reconstruct a local linear model

$$\begin{aligned}F(z) &= [AB][xu]' \\ &= Ax + Bu,\end{aligned}$$

and observe $w = Cx$. We calculate the condition for relative degree using the approximated C , A and B . If we choose N_r random z 's from the extended reconstructed space then we can calculate an average relative degree \bar{r} .

If we can determine \bar{r} reliably then we are in a position to "dictate" the form of our reconstructed model by listening to what Isidori tells us.

EXAMPLE

Consider Duffing's differential equation. This equation is given by

$$\begin{aligned}\dot{u} &= v \\ \dot{v} &= u - u^3 - \epsilon v + \gamma \cos(\omega t).\end{aligned}$$

We use parameter values which generate chaotic solutions, i.e., $\epsilon = 0.25$, $\gamma = 0.3$ and $\omega = 1.0$. We consider the system as a driven system with the input $g(t) = \cos(\omega t)$. If we observe the u -coordinate then the system has relative degree $r = 2$.

We generate a 10,000 point output time series by integrating the differential equations and outputting the u component every 0.05 time units. The input time series is obtained by evaluating $g(t)$ every 0.05 time unit.

In Figure 1 we show the results of applying our diagnostic to the “Duffing data”. We have chosen a lag of $s = 26$ by choosing the first minimum of the average mutual information function. The parameters used in the diagnostic were $k = 10$ (number of neighbours for local model), $N_r = 100$, and the decorrelation interval was 10. (This is necessary to avoid temporal correlation of the neighbours chosen to approximate the local models.) The input and output time series were normalised to have an equal variance of 2.

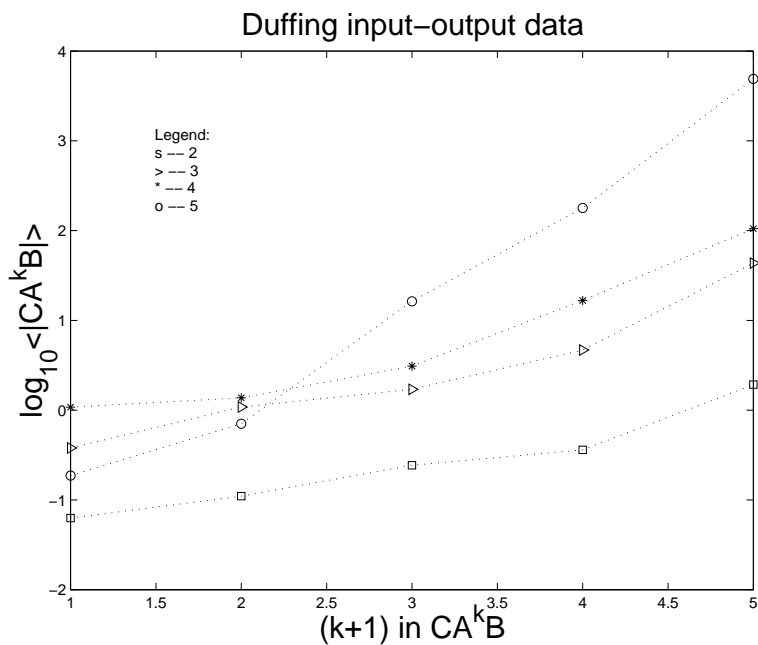

Figure 1: The calculation should give zero for $k - 1$ less than relative degree and non-zero for $k - 1$ greater than the relative degree. Obviously we have non-zero all the time so must look for a distinguished kink. None is apparent but the figure suggests $r = 2$ as expected. We note that the increase in the curves is most probably due to A^k rather than the extraction of relative degree.

The second example time series we use to illustrate our method is obtained by integrating the circuit equations of a model circuit for a (FET) oscillator. The circuit diagram for the oscillator is shown in Figure 2. We generate a

10,000 point input-output time series. The circuit equations can be derived using Kirchoff's laws. We integrate the circuit equations and output the state every 0.01 time units. The voltage measured at node 2 is considered the output time series and the voltage measured at node 4 is considered the input time series.

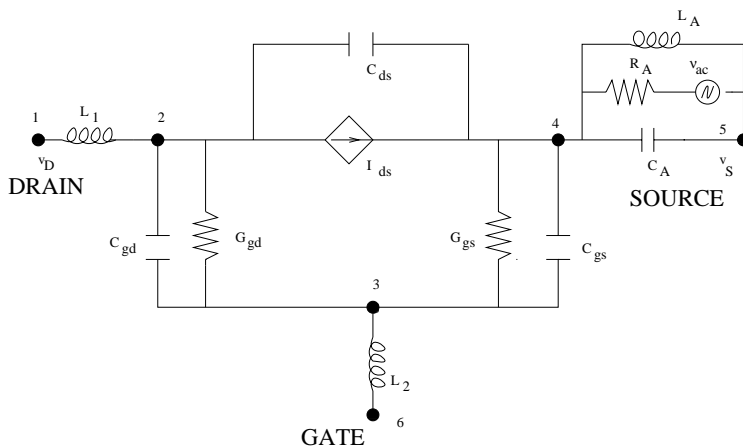

Figure 2: A circuit diagram of a nonlinear circuit model.

The results obtained by applying our method to the input-output time series data are shown in Figure 3. We used a lag of $s = 44$ and the parameters for the diagnostic were $k = 10$, $N_r = 100$ with a de-correlation interval of 10. We normalised the data sets to all have variance equal to 4.

3 USING NORMAL FORM STRUCTURE TO DETERMINE EMBEDDING DIMENSION

There is one striking difficulty with the above argument (other than the results are terrible). We know from Takens' results that for autonomous systems the reconstructed phase space should have dimension $d \geq 2n + 1$. Since $r \leq n$ (always) ... (elaborate)

This is not as tragic as it might appear. We can dictate $r - 1$ of the models components but must fit $d - r + 1$ components the hard way.

A question which arises is "Can we reconstruct the dynamics in a dimension d under the assumption that the relative degree $r = d$?"

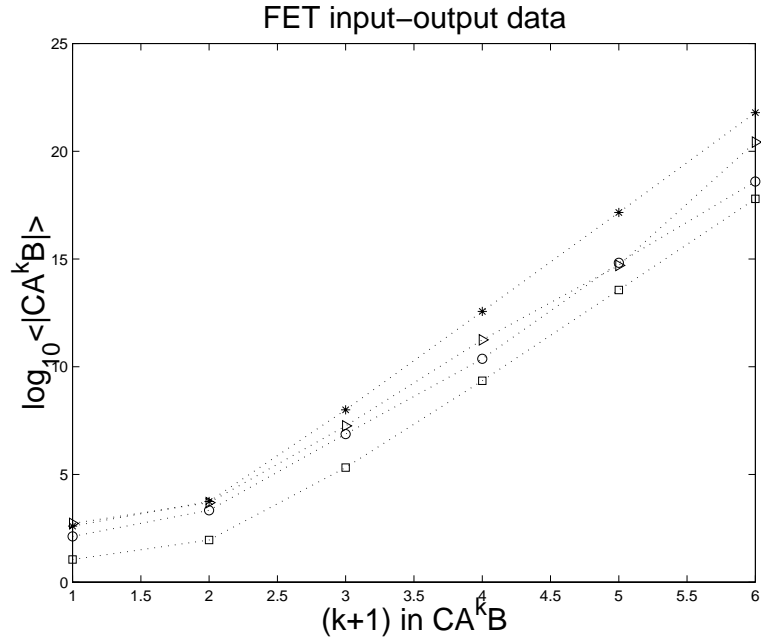

Figure 3:

Example: For a linear model with $d = 3$ we would have

$$A = \begin{bmatrix} 0 & 1 & 0 \\ 0 & 0 & 1 \\ a_1 & a_2 & a_3 \end{bmatrix}, \quad B = \begin{bmatrix} 0 \\ 0 \\ b_1 \end{bmatrix}, \quad C = [1 \ 0 \ 0].$$

This system has relative degree equal to 3.

It is clear that we can reconstruct the dynamics in the form of the above for any dimension $d \geq 2$. This suggests a procedure for finding a “best” d .

1. Reconstruct the vectors in dimension d .
2. Choose N_r random “centres” from the reconstructed vectors.
3. For each centre estimate a local linear model in normal form.
4. Calculate the modelling errors.
5. Calculate the average error over the N_r centres.

6. Choose the embedding dimension as d which minimises the average local errors.

In Figures 4 and 5 we show the results of the above technique to the Duffing and FET circuit data.

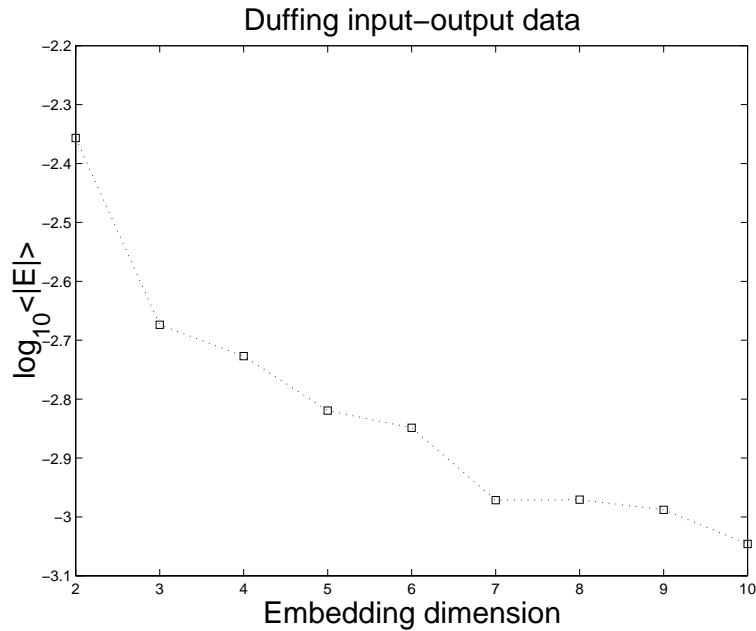

Figure 4: A plot of the average errors of normal form local linear models for increasing dimension.

4 CONCLUSION

The above report has suggested two methods to aid in the reconstruction of nonlinear dynamics from input-output time series. The first method introduced a method for the possible estimation of relative degree. The relative degree is an important concept in the theory of nonlinear control theory and being able to estimate its value from input-output data would be an advantage. The second method suggested a means to find an embedding dimension where “normal form models” could be reconstructed with accurate prediction performance.

We note that both suggestions failed.

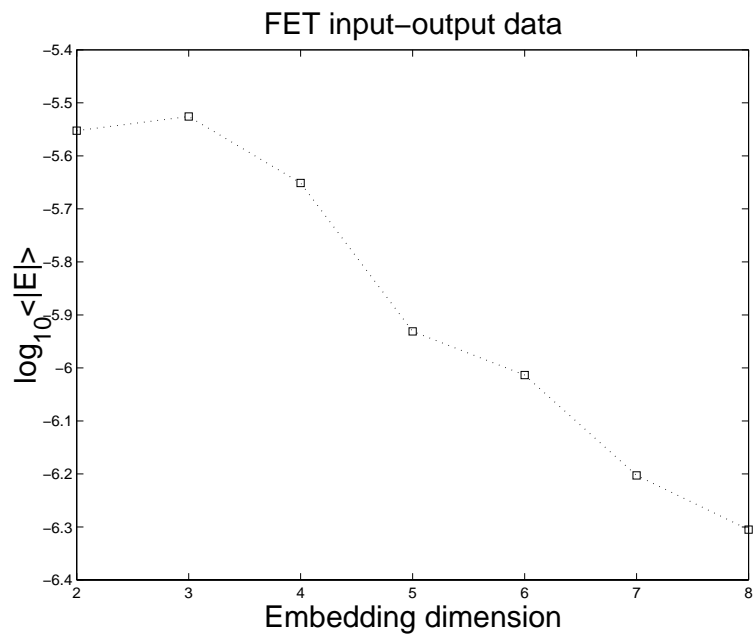

Figure 5: A plot of the average errors of normal form local linear models for increasing dimension.