

Next-Generation Inkjet Printhead Drive Electronics

By integrating the functions of four ICs into one new custom IC and then moving all the electronics related to the pens up to the carriage with the pens, significant savings were realized. A simple, low-contact-count, inexpensive flexible cable is used to connect the carriage to the main printed circuit assembly.

by Huston W. Rice

The project team for the HP DeskJet 850C printer developed the many elements of the printing system in parallel. In particular, the print cartridges (called *pens*) were new designs, along with the electronics that control them. As a result of the pens being new designs, their drive and control requirements were not completely defined, but were changing during the development program. The result of this was a system that worked well electrically, but was not fully optimized from a cost standpoint.

In particular, two aspects of the pen drive system presented opportunities for significant cost reduction. First, the flexible cable connecting the carriage and pens to the main printed circuit assembly was very elaborate and fairly expensive. Second, the electronics that control the pens were implemented in four different analog ICs, three of them custom ASICs.

With the advantage of being able to look back on the now well-defined system needs, a new approach was selected. By integrating the functions of the four ICs into one new custom IC and then moving all the electronics related to the pens up to the carriage with the pens, significant savings were realized. The new, highly integrated ASIC is less expensive to purchase and to assemble into the product. Since the signals are restricted to digital data and raw power, a simple, low-contact-count, inexpensive flexible cable is used to connect the carriage to the main printed circuit assembly.

For this design approach to be successful in the HP DeskJet 820C, several issues had to be overcome. For the greatest benefit, *all* of the electronics associated with the pens had to be contained on the carriage printed circuit assembly. Would it all fit? Because of a tight schedule and limited mechanical engineering staffing, no mechanical changes could be made to the carriage assembly to make more room. An additional mechanical constraint was that no components could be placed on the bottom half of the printed circuit board, which was needed for the connectors for the pens. To get the circuits to fit, all the analog IC functions had to be integrated into a single ASIC. Could all the different functions—power control, digital I/O, sensitive analog-to-digital measurements, power drivers—be integrated into a single device? If all the analog functions from four ICs were integrated into one IC, would there be thermal overheating issues in the IC? Would there be problems with radiated electromagnetic emissions from the digital interface to the carriage over a simple unshielded flexible cable?

To provide an aspect of excitement to the program, once this approach was chosen, there was no easy alternative to fall back upon if the above issues could not be dealt with. If this design failed, the whole HP DeskJet 820C printer program would be put in jeopardy.

Carriage Electronics Implementation

A key architecture change was made in the pen drive and control electronics in the HP DeskJet 820C compared to the DeskJet 850C. The power supply for the pens was modified in two ways. First, two independent dc-to-dc converters are used to supply power to the black and color pens in the DeskJet 850C. In the DeskJet 820C, a single pen power supply is used to drive both the black and color pens. Second, the control topology of the dc-to-dc converter was changed, as explained later in this article. The DeskJet 850C design requires seven large capacitors, two inductors, two power FETs, two power diodes, and several small discrete resistors and capacitors. All of this was replaced with two capacitors, one inductor, one power FET, one power diode, and one power resistor. This eliminates not only the need for several square inches of printed circuit board space that was not available on the DeskJet 820C carriage printed circuit board, but also the cost of the unneeded components.

The two pens in the product (black and color) must be driven at different voltages, and the DeskJet 820C design now only has one power supply, which is shared between the pens. This forced a change in the way printing is done. In the DeskJet 850C, both pens can be driven at any time, allowing maximum flexibility in how the printed image can be formed, and therefore maximum speed. In the DeskJet 820C, printing with the black and color pens alternates. For instance, black may be printed from right to left and then color from left to right. This difference costs a little in print speed for some color documents, but was key in enabling all the electronics to fit on the carriage printed circuit assembly.

Several techniques were used to integrate all the pen electronics onto the carriage for the HP DeskJet 820C. Beyond the power supply changes, the next most important step was designing a mixed-signal analog/digital/power ASIC that integrates all the functions required to drive and control the pens. The general strategy was to integrate all the relatively small-signal electronic functions into one ASIC to minimize the total component count. This both minimizes the cost and uses the minimum printed circuit board area on the very small carriage printed circuit assembly. However, to keep the ASIC silicon die area under control and to minimize the total power dissipated by the ASIC, several key components are not integrated. The power FET and diode for the dc-to-dc converter, both very large devices (from a silicon area point of view) are implemented as discrete devices externally. Two linear regulators are also implemented with off-the-shelf discrete devices to keep their power dissipation out of the ASIC package. Beyond these parts and some discrete capacitors and inductors that cannot be integrated, everything else is internal to the ASIC.

The process of developing the ASIC was the most difficult aspect of the carriage electronics design. Because of the high expected production volumes, at least two independent suppliers were needed. In the special mixed-signal/power IC industry, there is considerable process variation from one supplier to the next. However, only pin compatibility is required between sources. The two ICs do not have to be identical. Over a period of about six months, the analog ASIC was codeveloped by HP and the two suppliers. This allowed system design trade-offs to be made to keep both ASICs compatible. In addition, the overall program schedule demanded that the first pass of this full custom IC had to work, because there was only time for small revisions to the device before production started on the HP DeskJet 820C. As a result of excellent design teams at the suppliers and the careful codevelopment communication between HP and the suppliers, the first samples of the ASICs worked with only a few faults. Simple IC mask changes and the addition of a few small external components resulted in the system being completed on time.

In addition to the mixed-signal ASIC, three printed circuit board layout techniques were used to get all the components to fit. First, a 3D map of available space for components on the circuit board was generated. With this, small parts could be tucked under mechanical components, and the larger components could be carefully placed to avoid mechanical interferences. Second, the placement of the components was very carefully designed to minimize interconnect distances and the number of vias required. Third, the classical layout placement design rules that govern component spacings were pushed or outright violated. Breaking the rules was justified because the alternative was changing to a two-sided surface mount assembly process, which is a much more expensive and unattractive alternative.

In the end, all the parts were made to fit on the top side of the printed circuit board. An added benefit of the careful printed circuit board design is a very low-noise circuit. During the development process, we discovered many of the high-current switching circuits interfered with the sensitive measurement circuits. The compact layout provided significantly better performance than earlier prototype layouts.

As might be expected, the low-noise layout is also low-noise from an electromagnetic radiation point of view. Steps taken to control the slew rates of the digital signals on the flexible cable also proved effective in minimizing radiated emissions from the cable.

Finally, the steps taken to minimize the power dissipation in the mixed-signal ASIC were successful, to the point that the IC operates at junction temperatures less than 100°C under even the most extreme conditions.

Pen Operation

The black and color pens in the HP DeskJet 800 family of printers operate as a matched pair to deliver high-quality color documents. The pens themselves are in many senses the heart of the printer, and all of the electrical and mechanical systems are designed to support and optimize their performance. The electrical systems that drive and control the pens accomplish two major tasks: they maintain the temperature of the printheads to optimize the print quality, and they drive the correct inkjet nozzles at the right times to print the desired image on the paper.

The viscosity of the ink in the pens is sensitive to temperature, and the size of the drops ejected by the pens is sensitive to ink viscosity. By controlling the temperature of the pens, the viscosity and therefore the drop size can be controlled. Consistently sized drops provide the best print quality. Integrated into the pens is a temperature sensor, which can be used to measure and control the temperature of the pens, and therefore the ink viscosity and drop volume.

In previous generations of inkjet pens, the task of driving the pen nozzles has been fairly straightforward. The nozzles were arranged into columns on the pens, and every nozzle (or firing resistor) was controlled and driven directly. The pens in the HP DeskJet 820C printer have 300 nozzles (black pen) or 192 nozzles (color pen, 64 nozzles for each color). This high nozzle count makes it impossible to drive each nozzle directly with a dedicated signal and interconnection. For these high-nozzle-count pens, a matrix drive technique is used. The method is the same for the black and color pens. The matrix drive has two benefits. First, the number of connections to the pens is now much lower: 22 addresses and 16 columns can select $22 \times 16 = 352$ nozzles. The connection count is $22 + 16 + 16 = 54$. (The second 16 connections are for the column ground return currents.) Second, for power reasons, all the nozzles cannot be fired at one time. For each nozzle, a 2.5- μ s firing pulse is applied to the nozzle resistor that boils the ink and ejects the drop. The pulse voltage is about 10V and the current is 250 mA. If all 300 nozzles were driven at the same time, a total current of 75A at 10V would have to be available! This is impractical. For power reasons alone, all the nozzles cannot be fired at once, and the matrix drive provides a convenient way to distribute firing the nozzles in time.

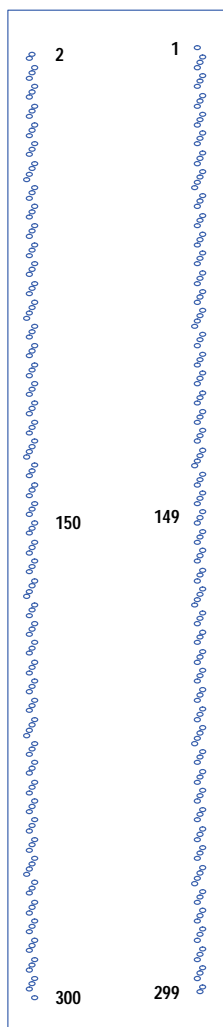

Fig. 1. Black pen nozzle placement.

The pen is electrically constructed as a series of 22 address inputs driving FETs in the rows of the matrix and 14 primitive inputs driving the firing resistors in the columns of the matrix. Inside the pen are selection FETs for each nozzle resistor; these can enable or disable a given nozzle.

The pen is driven one address row at a time. First, address one is driven, turning on the selection FETs for the top row of 14 nozzle firing resistors. Any of the 14 primitives are then driven (all, a few, or none) with the previously mentioned 10V, 250-mA pulse to fire the desired nozzles for each column associated with row 1. Address one is then turned off and address two is driven, selecting the next row of FETs and nozzle resistors. The desired primitives are again driven, but this time firing nozzles associated with row 2. This process is continued through address 22 and then repeated. By sequencing through all 22 addresses, every one of the 300 nozzles can be selected and driven. (Note: 22 addresses times 14 primitives yields 308 potential nozzles. Since the pen only has 300 nozzles, eight of the combinations do not have a selection FET or nozzle resistor.)

Mechanically, the pen nozzles are arranged in a pattern to generate proper images, even though all the nozzles are not fired at the same time. The black pen in the HP DeskJet 820C is capable of 600-dpi printing. The print swath (the band of ink printed in one pass) is 1/2 inch high, and the columns of dots in the swath are 1/600 inch apart.

A simple example will illustrate how the nozzles are arranged. Suppose we want to print a vertical line, 1/600 inch (one dot) wide. If the pen were constructed to fire all the nozzles at the same time to print a vertical column, the nozzles would be arranged in a vertical line on the pen. For power reasons, the nozzles are fired in 22 different groups of 14 (the 22 addresses and 14 primitives), and these are not all driven at the same time. Since the pen is continuously moving while the nozzles are fired, the desired vertical line would come out jagged or sloped if the nozzles were arranged in a straight line on the pen. To get a straight line on the page, the nozzles are staggered to compensate for the timing differences of the firing (see Fig. 1).

There is one additional complicating factor: The 600-dpi black pen has the nozzles arranged in two groups, odd nozzles in one column (with some stagger to compensate for the firing timing), and even nozzles in another column about 4 mm away.

Two nozzle columns allow 1/300-inch spacing between nozzles in a given column rather than 1/600-inch, making the pen easier to manufacture.

Now, to print a vertical, one-dot-wide line on the page, the odd nozzles are first driven, one address group at a time. Some time later, after the pen/carriage assembly has moved 4 mm and the even nozzles are over the same location on the paper, the even nozzles are driven, one address group at a time.

The implication is that the data sent to the pens must be sequenced properly to compensate for the nozzles being fired in 22 different address groups and also for the 4-mm odd/even nozzle spacing on the pen.

The color pen is constructed in a similar manner. Just like the black pen, the nozzles are fired one address at a time and are staggered on the pen to compensate for this. The first 16 of the 22 black address lines are shared between the black and color pens, while the color pen has its own unique 12 primitive lines. The 16 addresses times 12 primitives are sufficient to drive the 192 color nozzles, 64 per color. Like the black pen, the nozzles of the three colors are placed in dual odd and even columns. Between all the colors and the odd and even columns there are six different color nozzle placement columns, all with small-scale stagger. Therefore, for a color document, the sequencing of data is even more complex than for black printing. The data has to be timed for the address and row sequential firing, separated for odd and even nozzle columns, and timed to compensate for the displacement of the three colors with respect to each other.

The task of sequencing the data for the pen nozzles was traditionally handled by the printer digital electronics. In the HP DeskJet 820C, the Printing Performance Architecture (PPA) implementation moves the data sequencing task to the host PC and driver, where a lot of data processing was already being done. This relieves the printer of the burden of this data sequencing task, and allows it to simply drive the nozzles selected by the data coming into the printer.

Pen Drive Electronics Functions

The pen control and drive electronics have two key tasks. They provide the driving signals to eject the ink from the pens, and they provide a temperature control system to maintain a constant temperature in the active area of the pen. To accomplish this, the overall carriage electronics system has the following functions, most of which are integrated into the mixed-signal ASIC (see Fig. 2):

- Two-way digital interface between the pen drive electronics and the main digital controller ASIC in the printer (see article, page 1). Data is sent to the carriage to control which pen nozzles to fire during printing and to give control commands for the analog-to-digital converter (ADC), pen power supply, and other circuits. Pen measurements made by the mixed-signal ASIC are sent to the digital ASIC.
- 22 address drivers to provide the 12V signals to turn on the FETs inside the pens and select the correct row to be driven. These drivers are shared by the black and color pens.
- 26 column drivers to provide the high-current drive that fires the ink out of the pens. 14 drivers are used by the black pen and 12 by the color pen.
- A 30W, programmable dc-to-dc converter to provide precision power for the column drive signals.
- Two temperature control systems, one for each pen. This consists of an ADC to make calibration measurements on the pen temperature sensor, DACs to set target temperatures for the pens, and control comparators and logic to implement the temperature control system.
- Electronics to measure the pen firing resistors, to determine if the pen is damaged.
- Circuitry to provide thermal protection to the analog ASIC and resetting functions.

The overall system provides all of the means necessary for the digital ASIC and firmware to control the pens, both to maintain their target temperature, and to drive specific nozzles to print the images desired by customers.

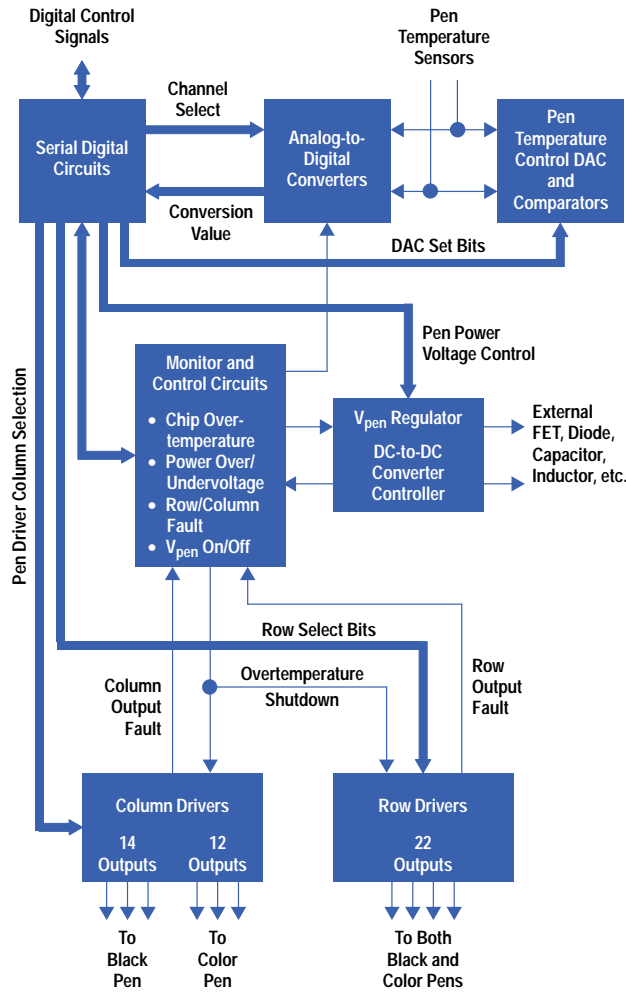

Fig. 2. Block diagram of the mixed-signal ASIC.

DC-to-DC Converter Design

The dc-to-dc converter that provides regulated power to drive the pens uses a new digital control technique. The feedback control of the regulator is a simple, purely digital system. If the voltage is too low, it turns on the regulator to full power and charges the bulk-storage filter capacitor to the target voltage as fast as possible. If the voltage is high, it turns off the regulator completely. Fig. 3 is a block diagram of the converter.

This control technique has several advantages:

- The control system is very simple and is easily integrated.
- The control system is inherently very stable and does not require additional compensation components or controlled values for the inductor and capacitor.
- The effective bandwidth of the regulator is very high, so it responds to changes in the load very quickly. Since the load placed on the regulator by the pens can change from 0 to 3A in less than 100 ns, fast response time is useful.
- As a result of the inherent stability and fast bandwidth, the size of the bulk storage capacitor could be reduced. Only one capacitor is needed in the HP DeskJet 820C design where three identical parts were used in the DeskJet 850C design. This was a key contributor to the goal of getting everything to fit on the carriage printed circuit board.
- Additional simple digital control functions, such as overcurrent and undervoltage shutdowns, were easily integrated.

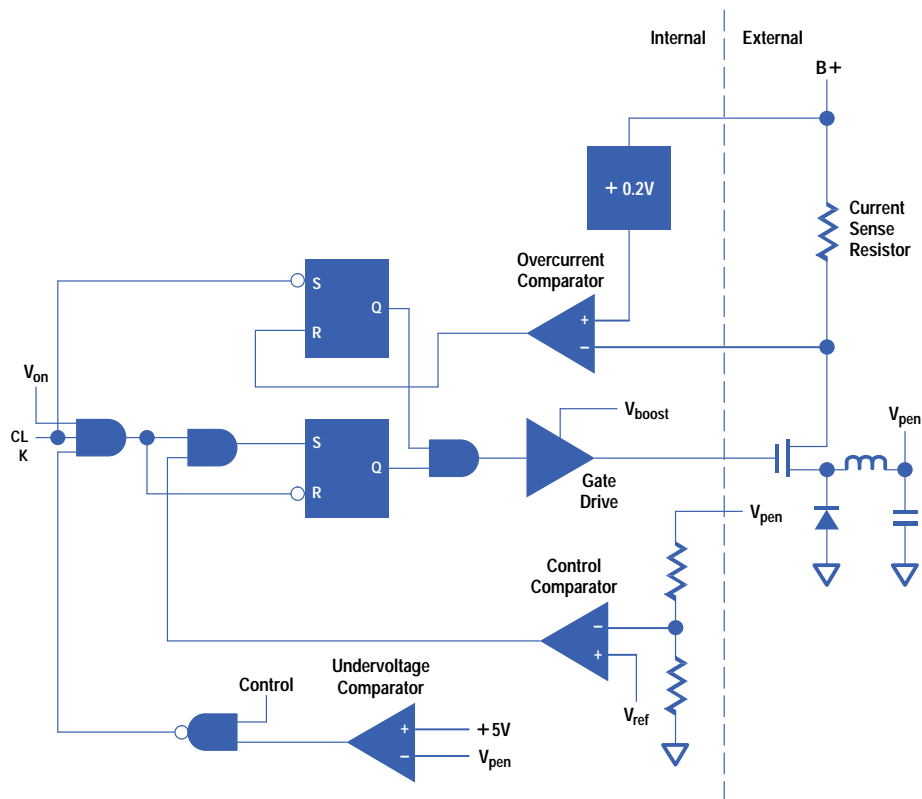

Fig. 3. Block diagram of the dc-to-dc converter.

Beyond the savings in components, the biggest benefit that this control topology presented was design flexibility. The definition of the mixed-signal ASIC, which contains the controller for the regulator, had to be finalized months before any testing could be started. By externally generating the clock for the regulator in the main digital ASIC under firmware control, changes could be made to the regulator *in software*, up to the day printer production began. Two of the key parameters in the design of any switching power supply are the switching frequency and the maximum duty cycle. By moving the generation of the clock frequency and duty cycle to the firmware and digital hardware, the final decision on the clock parameters could be delayed until the system was carefully tested and analyzed. For instance, as changes were made to the printed circuit board layout, the clock was fine-tuned to compensate for the differences in performance that were seen. The clock can even be dynamically modified to provide regulator behavior to match the printer operation mode at any given time.

The net result is very successful. The programmable clock was used to tune the regulator performance to match the system need after many prototypes had been built and characterized. The regulator switches 30W of power from a poorly regulated 18V supply to a very well-regulated, programmable voltage appropriate for either the black pen or the color pen. The regulator only uses about about 6 cm² (~1 in²) of printed circuit board area.

Acknowledgments

John Widder and George Barbehenn, both of the HP DeskJet 850C development team, provided vital consulting on the design of the pen drive and control systems. Mark Thackray and Leann MacMillian worked on the development and implementation of the serial digital interface for the mixed-signal ASIC. Mark Garboden and Carl Thompson wrote the firmware that controls all of the carriage electronics and integrated the assorted electronics components into a complete pen control system. Steve Stemple, the manufacturing support engineer for the HP DeskJet 820C, provided endless testing and design verification throughout the prototyping phases of the project.

-
- ▶ [Go to Next Article](#)
 - ▶ [Go to Journal Home Page](#)