

Print Cartridge Fixturing and Maintenance in the HP DeskJet 1200C Printer

The carriage assembly locates and transports the four print cartridges precisely. The service station provides capping, wiping, and priming functions for print cartridge maintenance and recovery.

by Michael T. Dangelo, Reza Movaghar, and Arthur K. Wilson

One of the main goals for the HP DeskJet 1200C printer was a narrow footprint so that the printer could be placed on a desk or existing desk stand. To achieve this goal, the carriage assembly and print cartridges are designed for minimum space between parts and for minimum overall width.

The overall width of the printer is dependent on the width of the paper plus two times the width of the carriage assembly. This is necessary to allow all of the print cartridges to print to the edge margin of the paper on each side.

The compact design makes it possible to register the four print cartridges accurately with respect to each other and with respect to the paper to ensure high print quality and high definition.

Design for manufacturing and assembly was considered from the beginning of the project. Areas of importance were low part count, modular construction, no adjustments, and ease of assembly. All parts either snap on, are nested inside other parts, or are held on with a minimum number of fasteners. The carriage assembly is modular in construction which allows subassemblies to be built and tested before being installed on the carriage.

Carriage Assembly Description

The HP DeskJet 1200C printer carriage assembly is built around a single-piece print cartridge housing, with all other assemblies and parts attaching to it. The carriage assembly includes a modular interconnect assembly, a paper sensor assembly, print cartridge bias and loading springs, slider rod bushings and preload pads, and the cover/trailing cable assembly, as shown in Fig. 1.

Print Cartridge Housing and Parts

The one-piece approach was taken to minimize tolerance buildups, maximize stiffness, and lower cost. This approach does have its drawbacks, however. To get a complex-shaped one-piece part with many features on all surfaces requires a very intricate and complex plastic injection molding tool.

To ensure the closest possible alignment of the print cartridges, the print cartridge datums in the print cartridge housing are machined relative to the slider rod axis to match actual operating conditions.

The print cartridges are located in the housing with biasing springs that push the print cartridges into position against the datums. Three sets of springs are used for biasing the print cartridges in the three respective axes. Of particular interest is the Z bias spring, which serves several functions. It pushes the print cartridge down to the bottom of the housing (Z direction), it clamps the top of the print cartridge in the housing, and it pushes the top of the print cartridge in the X direction against the X stops. The spring assembly nests in the housing and is held in place by the interconnect assembly.

Attached to the side of the print cartridge housing is the paper sensor. This is used to tell where the edge of the paper is and identify whether paper or transparency media is being used. The sensor assembly snaps onto the housing and plugs into the interconnect assembly.

The slider rod bushings, slide pads, and preload pads all snap or slide onto the housing and require no other attachment.

Interconnect Assembly

The interconnect assembly (Fig. 2) is modular in construction and is installed in the print cartridge housing as a complete unit. The backbone of the interconnect assembly is a one-piece frame with alignment pins and holes for obtaining proper alignment of parts and for positioning in the print cartridge housing.

Attached to the frame is a one-piece flexible circuit that makes electrical contact with all four print cartridges and with the carriage print cartridge driver board (carriage board).

The flexible circuit interconnect pads are positioned against the print cartridge contacts with an elastomeric pad. This pad is backed up with a spring-loaded plate, which supplies the force required for electrical interconnect. This system allows a long interconnect distance and also gimbals to align the face of the interconnect with the print cartridge contacts.

Also included in the frame are encoder strip guides. These guides align the encoder strip to an encoder for determining carriage position and velocity, which is attached to the carriage board.

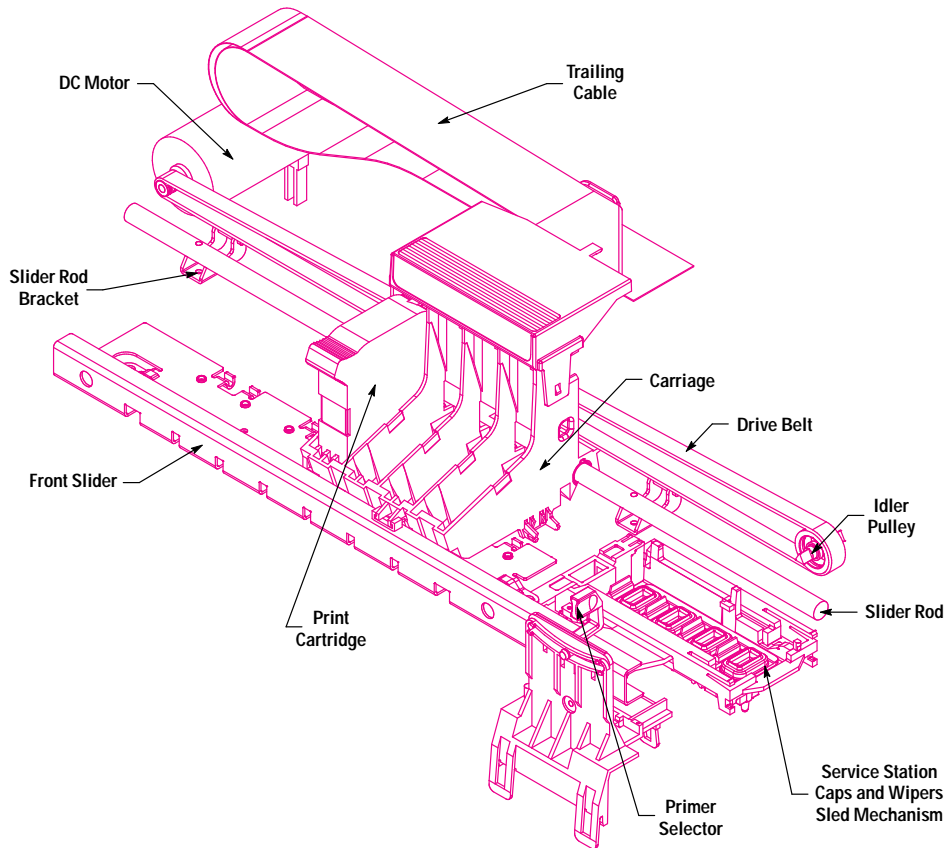

Fig. 1. Isometric view of the DeskJet 1200C carriage assembly: the carriage with a print cartridge, the carriage drive and support, and the service station.

The carriage board has a number of functions, the primary one being to drive the print cartridges. On this board are the encoder, connectors for the trailing cable and paper sensor, and electrical interconnect pads for connection to the flexible circuit.

Pressure is used for the electrical interconnect of the carriage board to the flexible circuit. An elastomer strip is nested in the frame and forces the flexible circuit against the carriage board contact pads. The carriage board is clamped to the frame along the contact area with three screws.

The carriage board is aligned to the frame and flexible circuit with two locating pins. This provides for proper positioning of the flexible circuit to the carriage board and aligns the

encoder in the frame. The carriage board is positioned vertically in the carriage assembly. This allows the trailing cable to attach directly to the top of the board using minimum space.

The interconnect assembly is positioned in the carriage by two pins and the center print cartridge wall. It holds the print cartridge clamp spring in place and positions the print cartridge interconnect circuit. The complete module is held in the carriage assembly with one screw.

A cover that snaps onto the carriage protects the print cartridge clamp spring, positions the trailing cable, and hides electrical components from view.

Carriage Axis

In the DeskJet 1200C printer, the black and color dots are laid down on the media by a scanning printhead. A well-supported and controlled print cartridge carriage axis is essential for accurate dot placement and optimum print quality. The distance between the printhead and the media is another important variable in print quality and has to be set nominally within small tolerances. This has to be achieved by simple adjustment within a few seconds. The scanning head also determines the footprint and compactness of the print engine, which affects the desktop nature of the product and the shipping cost. Low cost is the major constraint imposed by high-volume requirements.

A two-dimensional side view of the carriage axis and drive is shown in Fig. 3. A linear encoder with a resolution of 150 lines per inch determines the absolute position of the printhead. Servo control of the carriage is based on the quadrature output (4×150 counts) of the optical encoder, and is updated every 0.002 second. A state-space model was developed using

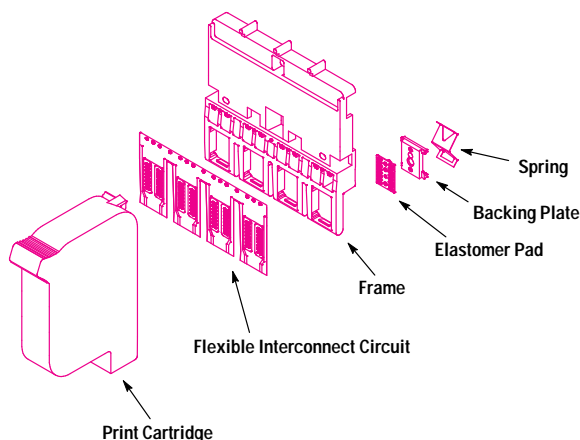

Fig. 2. Print cartridge interconnect assembly.

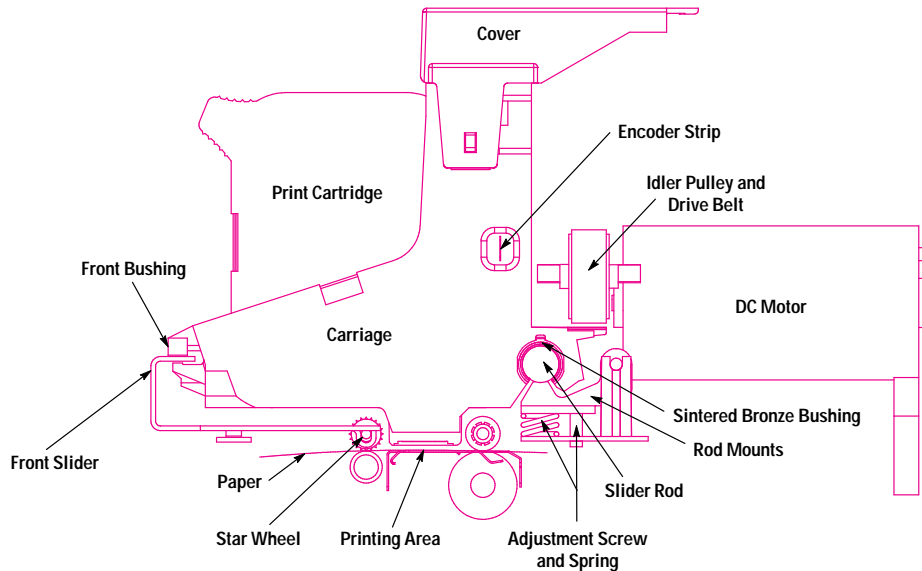

Fig. 3. Side view of the carriage axis.

the MATLAB software package to simulate the open-loop and closed-loop behavior of the dynamic system. Real position and estimated velocity feedbacks are optimized for maximum velocity stability (i.e., velocity variation $\leq 5\%$ of slewing speed) as a function of carriage mass. The mass of an empty carriage is 36% of the mass of a carriage with four full cartridges.

As shown in Fig. 3, the encoder strip, print cartridge nozzles, slider rod, and timing belt are located close to each other to minimize the vibrations of the carriage both in rigid and non-rigid mode. The carriage is supported in front by a sheet-metal piece called the front slider which is also a functional part of the media axis and holds eight star wheels to control the media path. The sliding surfaces are a molded acetyl piece on the carriage and a polyethylene tape on the front slider. These two surfaces reduce the friction, noise, and wear considerably. The friction reduction in the front reduces vibrations caused by this force. The only slider rod in the machine is 3/8 inch in diameter and is supported at two midpoints by two identical stamped sheet-metal parts called rod mounts. The midpoint supports have several advantages: small rod diameter, high natural frequency, small footprint, and ease of print-cartridge-to-paper height adjustment.

The rod mounts rest on two compression springs. Two tap-tight screws hold the mounts against the springs, going through a sheet-metal part sandwiched between the top and lower chassis. These two adjustment screws control the print-cartridge-to-paper height. The height adjustment is done at the assembly line. The print cartridge gauge is inserted in the black stall of the carriage for height adjustment to maximize the text print quality.

The main bushings are two split C shapes made of powdered sintered bronze with impregnated oil. This type of bushing has good friction characteristics and is very cost-effective. The rotational dynamics and chatter effect of the carriage in unidirectional and bidirectional printing are minimized by a preload bushing and spring that bias the carriage with respect to the slider rod, as shown in Fig. 4.

The carriage is driven by a direct-drive dc motor through a tensioned timing belt. The dc motor and tensioner are part of the upper chassis of the printer. The carriage trailing

cable rests on the upper chassis and sweeps in a minimum space between the top case and the upper chassis.

Service Station

Inkjet technology has come a long way since 1984, from the first printhead with twelve nozzles to the current 104-nozzle DeskJet 1200C printhead, but one thing has remained a struggle: maintaining a clean nozzle plate. Nozzle plates tend to crust externally with everything from dried ink to paper fibers. Nozzle plates tend to crust internally with everything from ingested paper fibers to dried ink. The challenge of the service station engineer is to keep the external surface of the nozzle plate clean with a minimum of hardware (wipers, caps, etc.), and to provide a fairly painless method of correcting a printhead that has succumbed to external or internal contaminants (priming, spitting, pulse warming). Thus the challenge includes both preventive maintenance and recovery. Fig. 5 shows the DeskJet 1200C service station.

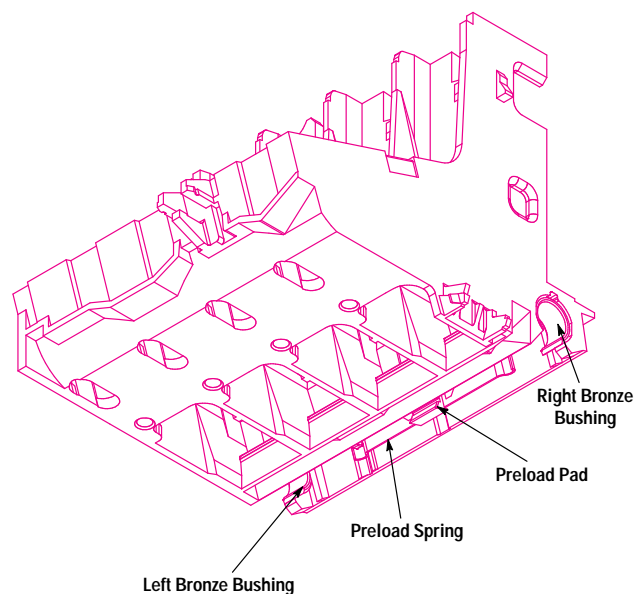

Fig. 4. Bottom view of the carriage, showing antichatter bushing and spring.

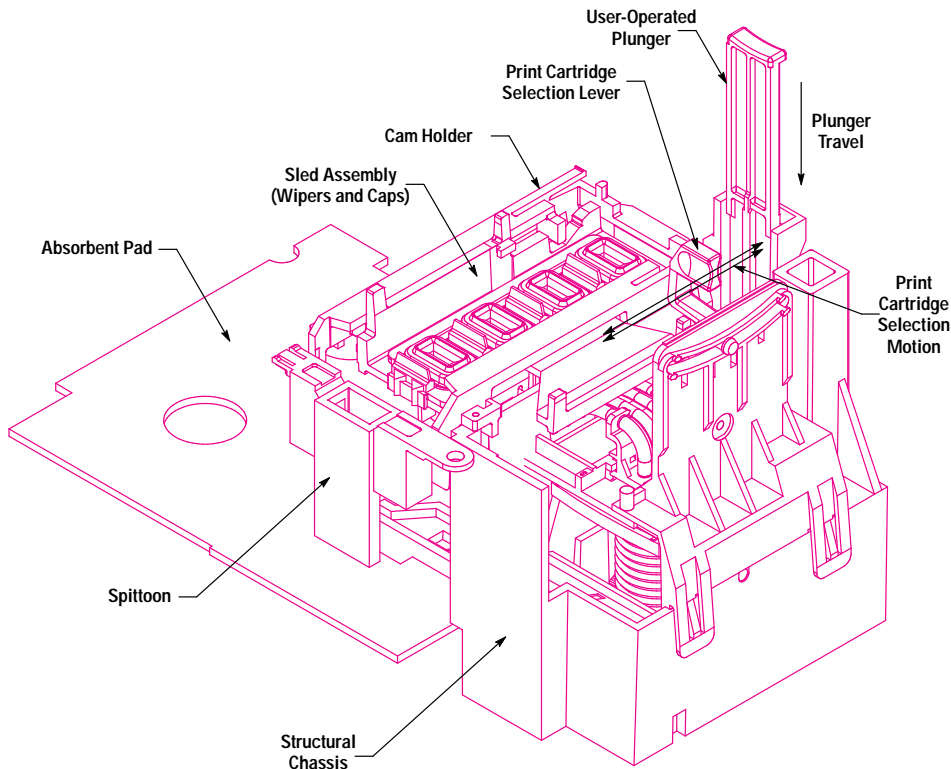

Fig. 5. Isometric view of the service station.

The key components of a thermal inkjet service station are the cap, wiper, primer, and associated mechanisms that allow these components to interact with a printhead.

Cap. To prevent the printhead from drying out when not in use it needs to be stored in a high-humidity sealed chamber. The main function of a cap is to provide a seal between the chamber and the printhead. Previous products have chosen to seal the cap against the nozzle plate at the plate surface. One disadvantage of this method is that the cap alignment to the printhead must be near perfect (nominal clearances of less than 1 mm as shown in Fig. 6a) because if the lips of the cap seal against one of the nozzles, capillary action will draw ink from within the reservoir inside the print cartridge. The result is a messy service station and an unhappy customer.

Early in the development of the DeskJet 1200C the print cartridge and product engineers decided that the best surface for a cap seal is well outside the nozzle plate. In the DeskJet 1200C the nominal clearance is closer to 3 mm as shown in Fig. 6b.

Wiper. The wiper removes external debris from the nozzle plate without scratching the thin gold protective layer. Any particle in or around the nozzle will misdirect the ink droplet or completely block it from ejecting. In a perfect world the nozzle plate would always be sparkling clean. Thermal inkjet inks are designed to dry quickly and permanently, so if wet ink is allowed to dry on the nozzle plate it becomes very difficult to redissolve and wipe away. Wipers have not changed much from their initial development.

The DeskJet 1200C uses a standard-geometry wiper that looks much like an automobile windshield wiper. Design considerations include material geometry, angle of attack, abrasion and wear resistance, ink compatibility, manufacturability, ease of assembly, user replaceability, and performance over life.

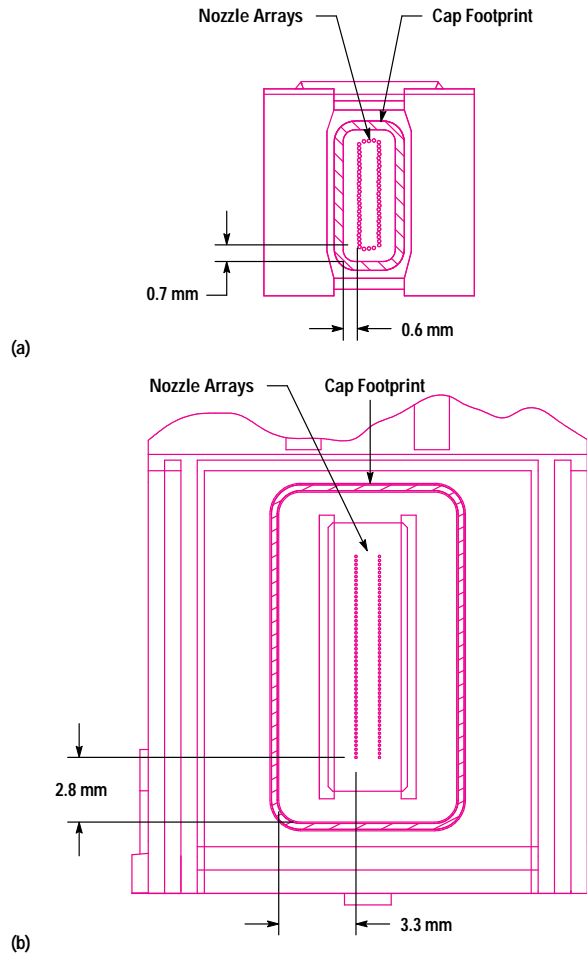

Fig. 6. Nominal clearances between cartridge cap seal and nearest nozzle. (a) DeskJet print cartridge. (b) DeskJet 1200C print cartridge.

Mechanism. Because the DeskJet 1200C is a low-cost, high-volume product, the service station mechanism is designed with a very low part count. Excluding the caps and wipers, the preventive maintenance mechanism consists of only five parts while the priming mechanism consists of 18 individual parts.

The sled assembly is activated in the X direction by print cartridge carriage motion and in the Z direction by four cam surfaces. The capping and wiping forces are a result of two identical wireform springs attached at one end to the structural chassis and at the other to the sled assembly. The cam surfaces are designed to wipe the print cartridge only as the carriage exits the service station on the way to printing. Fig. 7 shows the sled assembly in three different positions.

Maintenance. During certain times it is necessary to spit ink from each nozzle into a reservoir. This purges ink from the nozzle region after extended capped storage, after wiping or priming, and within certain plots. Directly to one side of the service station is a spittoon for this purpose. The spittoon is designed as a bottomless pit with a large-surface-area absorbent to contain as much as four full print cartridge volumes.

Priming. Priming is the drawing of large volumes of fresh ink through clogged nozzle orifices. This action will clear crusted ink both internal and external to the nozzle plate, and will purge small trapped air bubbles. In keeping with the theme of low cost and low risk, the DeskJet 1200C priming system mechanism was leveraged from the PaintJet XL300

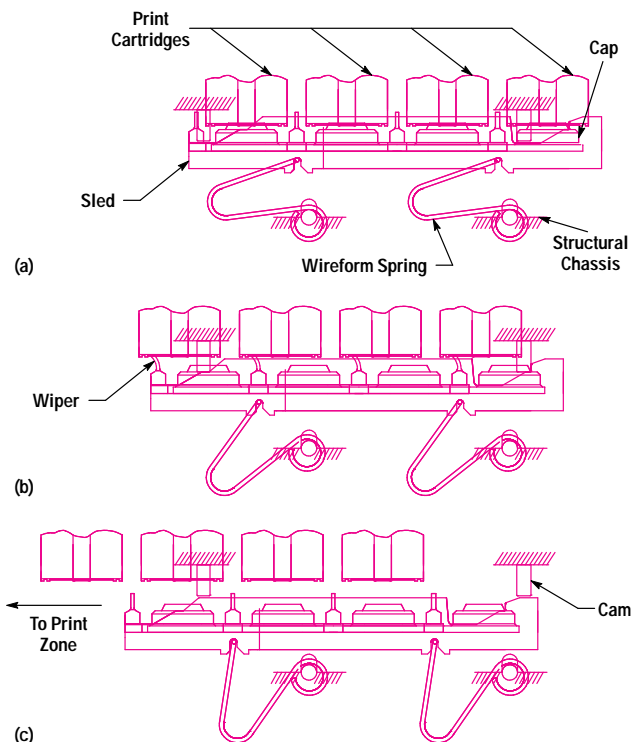

Fig. 7. Three positions of the sled assembly. (a) Print cartridges capped. (b) Wiping print cartridges. (c) Print cartridges clear of caps and wipers, ready to print.

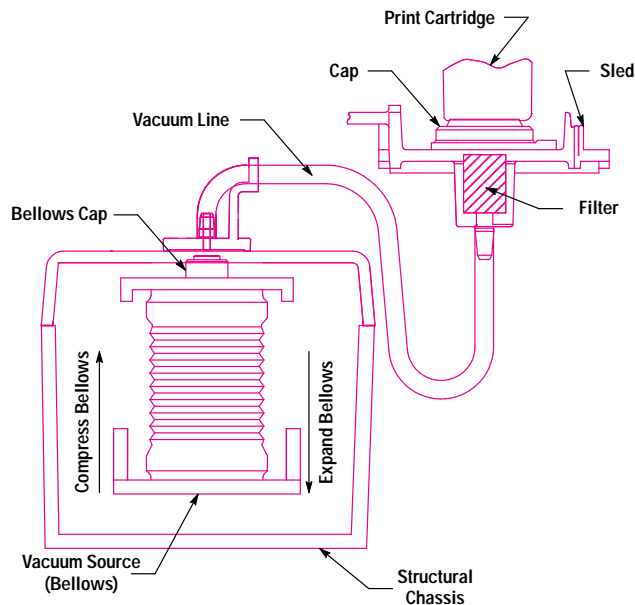

Fig. 8. To prime the print cartridge, the user compresses the bellows using the plunger. The bellows cap seals to the vacuum line and the bellows expands and draws ink from the print cartridge nozzles.

printer (see Fig. 8). To improve on the usability of the system the priming source is routed via four tubes to the service station sled. The user selects which print cartridge is to be primed by positioning a lever directly in front of the print cartridge. The user then actuates the vacuum source by depressing a plunger with a vertical stroke. Audible feedback from the mechanism signals to the user that a corrective action has taken place.

The primer tubes have a tendency to clog with dried ink over the product's life. To address this issue the ink is kept from entering a tube by a filter between the print cartridge and the tube. During a prime the majority of ink removed from the print cartridge remains on the nozzle plate and is cleaned off by the wiper. Any ink drawn down away from the print cartridge is trapped in the filter and does not enter the tube.

Acknowledgments

The authors would like to acknowledge Bill Osborne for his early development work on the service station and Heinz Waschhauser for his refinement and completion of the design. Ron Askeland, Michele Shepard, Frank Drogo, Jason Arbeiter, and Dennis Desouza provided countless hours of support to the service station testing program. For his efforts on the implementation of the service station algorithms, Bill Hilliard deserves special mention. Wistar Rhoads' great contributions to the carriage architecture made the printer design both compact and low-cost. The tooling expertise of Walt Borra, Walt Auyer, and Warren Werkmeister made the very aggressive development schedule possible. Dennis Culver, Richard Berkold, and the entire model shop staff organized and delivered parts on time for all the prototype builds.