

Inkjet Printer Print Quality Enhancement Techniques

Five print modes, each optimized for quality and throughput, HP Resolution Enhancement technology, heaters to dry the ink and the paper, and accurate print cartridge alignment and paper advance schemes contribute to the high print quality of the HP DeskJet 1200C printer.

by Corinna A.E. Hall, Aneesa R. Scandalis, Damon W. Broder, Shelley I. Moore, Reza Movaghar, W. Wistar Rhoads, and William H. Schwiebert

When the concept for the HP DeskJet 1200C printer was formulated, the design direction chosen was a text printer that also had excellent graphics performance. The initial decisions were fairly easy to make. For example, the printer was to be thermal inkjet with a resolution of 300 dots per inch (dpi). It was to be media independent (i.e., not just "special" media) and it was to have four print cartridges (black, cyan, magenta, and yellow) and most probably fast and high-quality printing options. To accomplish these objectives, the chosen printing system was a scanning carriage to hold the four print cartridges and a heated paper path to dry the ink quickly.

Having chosen a design path, each part of the writing system was investigated to determine how its contributions to print quality could be optimized. A dual approach was taken. Each print mode was designed to give the customer the best output in the least amount of time.

Improvements were made in various mechanical designs that optimize print quality in all print modes. While the DeskJet 1200C has five print mode options, those for transparency film and glossy media are not covered in this article. Print modes for plain paper (e.g., copier paper) are described briefly with an emphasis on optimizations that improve quality or throughput.

The mechanics and firmware that are common to all print modes were optimized with good overall print quality as the goal, and were also optimized specifically to improve known defects within a single print mode. The designs highlighted in this article are the main heater, the media preheater, the carriage encoder and print cartridge alignment scheme, and the paper advance accuracy.

Print Modes and Optimizations

Three plain paper print modes are available to the DeskJet 1200C user: fast, normal, and high-quality. Each print mode is capable of printing both text and graphics. While there are many subtle differences between the modes, the main differences are in the number of passes and the optical density of the black. The rate at which the ink can be dried is the main limit to throughput. Ink applied too fast will cause color bleed because of dye mixing at color boundaries, buckled paper from expansion of paper fibers, and mottled colors. Multipass printing can eliminate these defects by allowing

the ink to dry between passes. For example, a two-pass mode prints only half of the ink on the first pass and an additional scanning pass of the print cartridge is used to apply the rest of the ink. Multipass printing takes longer than single-pass printing, but quality is improved. Black optical density, especially in text, follows a similar pattern, trading off speed for quality. Applying more black ink to the same area and increasing the optical density requires more time to dry while improving quality.

Fast mode is just that—text speed is six pages per minute and graphics speed is under one minute per page. This speed is achieved by single-pass bidirectional printing, and consequently there are some of the defects listed above when printing high-density graphics in fast mode. Although text quality is still quite good, all 104 nozzles of the print cartridge are fired without regard to character splitting (i.e., a line of characters may be printed in two separate sweeps, top half first and bottom half second). While this mode is not recommended for high-density graphics, it will give the customer feedback about the colors chosen and the location and size of the graphics. Since this mode is heavily skewed towards speed and not quality, one way in which this mode was optimized was in the amount of time the heater is given to warm up the writing zone. Print quality is best when the writing zone is allowed to stabilize at the optimum temperature, but warm-up time requires the customer to wait. To avoid this wait, the printer will only warm up for the amount of time needed to receive the file. If the file is small the printer will begin printing almost immediately. The compromise works well for text and low-density graphics files.

The speed and print quality in fast mode are different from high-quality mode. Both text and graphics quality are improved in high-quality mode. Throughput is slightly reduced to four pages per minute for text and two minutes per page for graphics. Text is darker, and characters are not split and have smoother edges than text in fast mode. Through the use of a three-pass print mode, color-to-color boundaries are crisp and pass-to-pass paper advance errors are blended and distributed. Trade-offs made in this mode favored quality over throughput, although there are three notable exceptions. As mentioned above, three passes are used. Many numbers of passes were investigated, but when the improvement in quality (with more passes) was measured against print time,

the winner was three passes in terms of acceptable quality and speed. A similar decision was made with respect to slowing down a plot for very dense graphics. The longer the inked paper is over the heater, the more the ink dries between passes, reducing bleed and cockle. The printer is able to recognize dense graphics in a plot and slow the printing to allow for more drying. However when quality improvement and slowdown are compared, a point is reached when more slowdown gives only a small amount of quality improvement. For this reason, the slowdown equation has a hard-clip limit on the maximal time to print a plot.

The last example of how speed is maximized with minimum effect on quality involves how black is printed. High-quality text has the scan-axis resolution enhanced from 300 to 600 dpi as described below. Since the printer may not always know when a plot has changed from text to graphics, it is necessary to print all black in this 600-by-300-dpi format when using high-quality mode. Printing at 300 dpi in the scan axis takes all of the available firing windows, so the printer cannot print 600-dpi black and other colors in the same swath unless the carriage halves its speed or a separate swath for black is used. Both options severely degrade throughput. However, as detailed below, the position of the carriage and thus the position of the drops in the carriage scan axis are well-characterized on the DeskJet 1200C. Harnessing this accuracy is the key to being able to print black on the scan that would normally be the carriage return (retrace). Throughput is good, since no time is lost in a carriage return. Good dot alignment in both directions allows all the color to be printed on the forward pass and black to be printed on the retrace while the carriage is traveling at almost two-thirds the usual carriage return velocity.

Normal mode is the third plain paper print mode option. Color printing is identical in normal and high-quality modes. Normal mode text is printed with the same resolution as fast mode: 300 dpi. Text printed in normal mode will always have white space between swaths as in high-quality mode. In this mode, a customer can have full-quality graphics with nearly the text speed of fast mode (six pages per minute). Additionally, because 300-dpi dots appear smaller than 600-dpi dots, this mode works well for images where small dots reduce the overall grainy appearance of the print. Because this mode is a mixture of fast and high-quality modes, during the development of the printer the quality and throughput of normal mode were both subject to modification to achieve the best mix. For example, the initial implementation of normal mode printed all black text and black graphics (anything other than text is considered graphics) in one pass, that is, all nozzles ready to fire. This worked well for spreadsheets, but not so well for images and business graphics. To improve the quality, all black-only graphics are printed in three passes to maintain superior quality. The trade-off for quality was worth the longer printing time.

Resolution-Enhanced Text

HP Resolution Enhancement technology (RET) is a technique used to improve text quality by increasing the effective resolution of an image and selectively placing or deleting dots to improve the overall smoothness of the character. Used on inkjet printers, RET increases the effective resolution from 300 by 300 dpi to 600 by 300 dpi. The edges are smoothed by

applying rules that are triggered by the detection of a specific pattern of dots.

The following considerations influenced the design of the inkjet implementation of RET. First, enhancement via RET should never degrade and in most cases should improve text quality. Second, the inkjet implementation of RET had to conform to the low-cost goals of the printer. This limitation directly impacts the size of the rule set, since the rules are embedded in the ASIC (application-specific integrated circuit). Finally, the implementation must not impact printer throughput.

With these considerations in mind the primary goal of any implementation of RET is to "smooth the jaggies" inherent in any discrete dot placement technology by effectively increasing the resolution without actually transporting the data twice. While achieving smoother lines, the stroke density and weight must be preserved. These goals are accomplished by defining a specific rule set that fits within the cost constraints of the hardware. These constraints force the inkjet implementation of RET to target the most apparent causes of poor text quality and to limit the rule set accordingly.

Other limitations of the inkjet implementation of RET are the small size of the pattern recognition window and the possibility of enhancement only along one axis. The size of the pattern recognition window allows most characters to be improved; however, patterns not recognizable within the limited window size will not be enhanced. The inkjet implementation of RET enhances near-vertical edges of text in portrait orientation. Characters in landscape orientation will not improve as much, since most character edges when oriented for reading are near-vertical.

RET was first implemented on the HP LaserJet Series III printers. The inkjet implementation of RET is significantly different in several respects. The most significant is that the LaserJet printers are capable of controlling both dot timing and intensity. This allows the LaserJet printers to enhance both vertical and horizontal edges. Also, on the LaserJets the RET function has its own dedicated ASIC whereas the inkjet implementation fits RET onto the print-engine ASIC. The inkjet rule set was determined statistically by testing the LaserJet rule set and using only those rules that occurred a significant number of times per page.

Each RET rule consists of two parts: a pattern and an action. When the pattern is recognized the associated action is performed. The action consists of setting or clearing a bit or a set of bits. Fig. 1a depicts a pattern detected within the unenhanced image. Fig. 1b depicts a possible action associated with the pattern in Fig. 1a. Fig. 1c shows a possible unenhanced portion of an image containing the pattern shown in Fig. 1a. Fig. 1d shows the result of applying the rule to the original image.

The edge smoothing effects of RET are easily seen in the photomicrographs of Fig. 2.

Mechanical Improvements

Within each print mode, a variety of writing system designs affect print quality. The effect of the main heater is enormous. It is located directly below the print zone (see Fig. 3) and functions to dry the ink quickly. It prevents objectionable

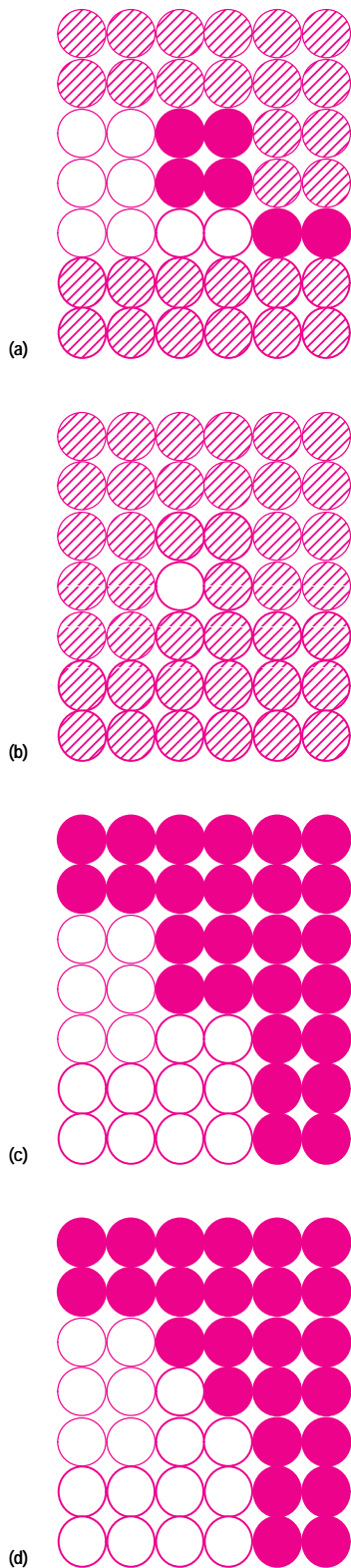

Fig. 1. (a) A pattern detected within an unenhanced image. The striped circles represent pixels that can be on or off (“don’t care”). Empty circles represent pixels that are off and solid circles represent pixels that are on. (b) A possible action or rule associated with the pattern in (a). The striped circles represent pixels that will not be changed. Empty circles represent pixels that will be changed from on to off. Solid circles represent pixels that will be changed from off to on. (c) A possible unenhanced portion of an image containing the pattern shown in (a). (d) The result of applying the rule to the original image.

bleed and paper cockle (out of the plane puckering of the paper caused by the aqueous nature of the ink) while increasing throughput.

The heater consists of a wire element which, when heated, radiates in the 3-to-5-micrometer range. This is the optimum range to excite and evaporate water molecules. The element is suspended in a quartz tube which is housed in a three-sided reflector which directs the radiation in the printing area. When the ink is dried quickly, the water does not have a chance to swell the paper fibers and produce cockle, nor to mix with an adjacent wet drop of ink and produce bleed.

If there is a data interruption or an I/O delay, the heat from the main heater runs the risk of discoloring (browning) the paper or causing a hue shift when a given swath of printing is dried for longer than the previous or succeeding swaths. To prevent these objectionable print quality errors, the printer constantly monitors the data buffers, and as soon as it sees the data rate slowing down, the printer begins to ramp down the print speed and turns off the heater. In this way, the hue shift is hidden by making it appear more gradual, and browning is prevented by reducing the heat. The reduction in throughput coupled with the reduction in heat maintains the print quality and does not adversely effect bleed or cockle.

One of the challenges of printing in a heated writing system is paper shrinkage. If paper is allowed to enter the heated print zone without being preconditioned, the paper will shrink during printing. In single-pass printing this shrinkage shows up at the swath boundaries as a misregistration. For example, a vertical line placed near the edge of the media will look like stairsteps. In multipass printing, the errors will show up as individual misregistration of dots. In an area fill, this appears as a white haze. Different environmental conditions and different media types will affect the amount of error that occurs. Humid conditions and heavy bond papers will produce the worst errors.

The DeskJet 1200C preheater is designed to precondition paper evenly before it enters the print zone. The heater consists of a flexible polyimide laminate with etched copper traces. The power is regulated by the resistance of the preheater itself, which eliminates any cost of supplying a pulse width modulated or other regulated voltage. If the preheater is cold when the printer receives a print job, the cold preheater draws approximately 45 watts. As the copper traces become hot and the resistance builds, the preheater consumes a much lower steady-state power.

One of the design criteria considered during development was warm-up time. By using a thin laminate (less than 0.010 inch) and suspending the preheater away from any large thermal masses, the warm-up time is reduced to less than four seconds. This is less than the time required to feed a sheet of paper and start printing. In this way, the time spent preconditioning the media is free and throughput for the customer is unaffected.

While the preheater minimizes the adverse effects of media shrinkage on dot placement, other factors that greatly affect dot-to-dot alignment are the accuracy with which the media is advanced, the control of the carriage scanning velocity, and the success of the carriage in reliably aligning four print cartridges.

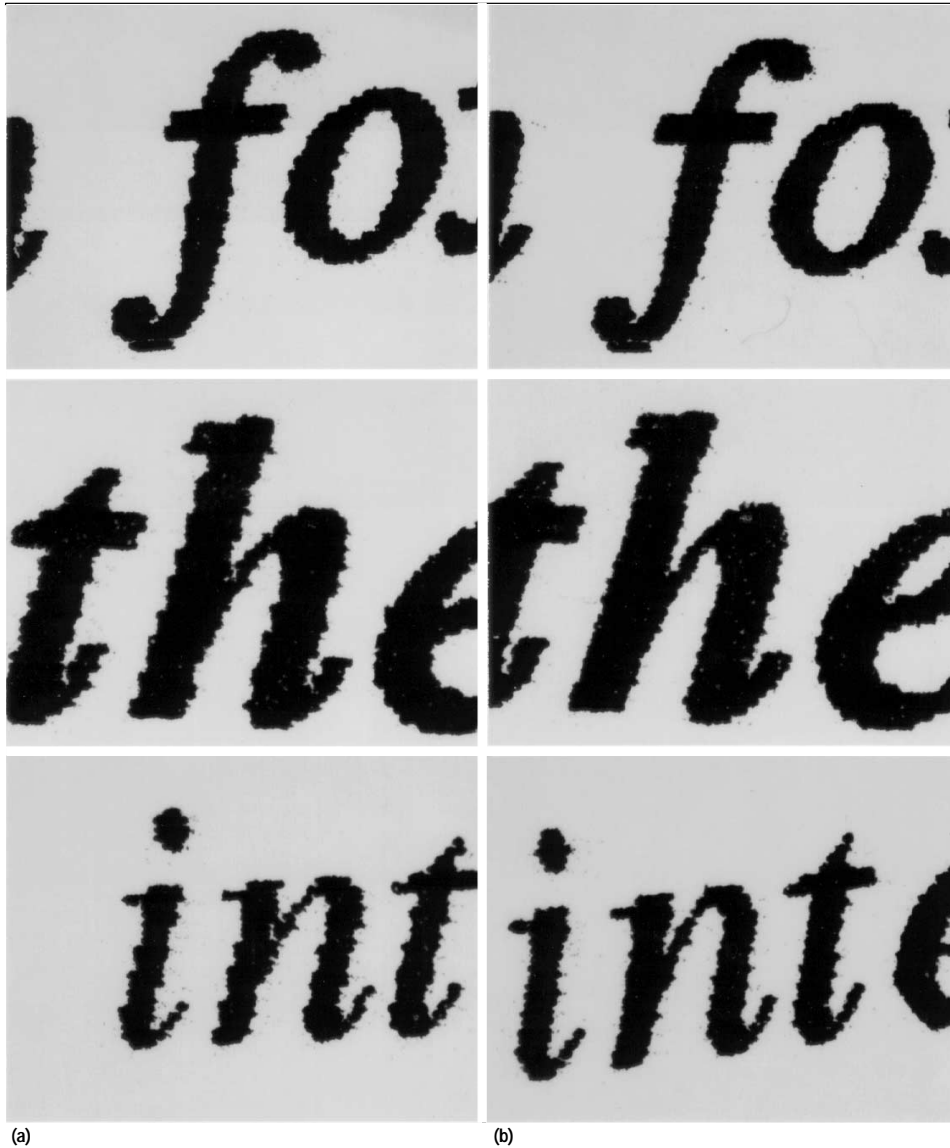

Fig. 2. Examples of the edge smoothing effects of HP Resolution Enhancement technology (RET). (a) Unenhanced text characters. (b) The characters in (a) after the application of RET.

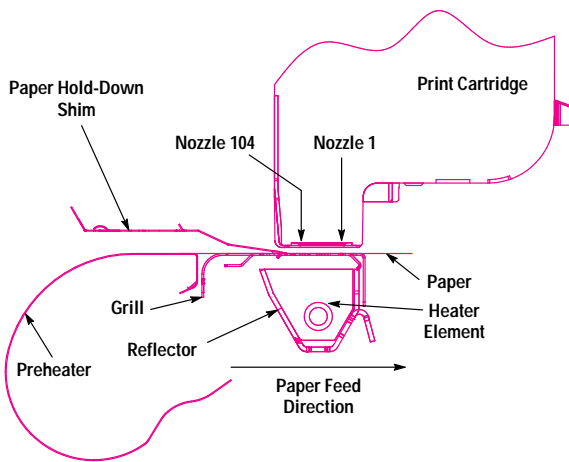

Fig. 3. HP DeskJet 1200C printer writing system.

Carriage Position

The position of the carriage as it scans the paper is controlled by a linear encoder with a resolution of 150 lines per inch. Servo control of the carriage is based on the quadrature output (4×150 counts) of the carriage-mounted optical encoder and is updated every 0.002 second. The velocity is maintained by real position and estimated velocity feedback. Firing pulses are generated by an extrapolator from the rising edge of a single channel of the encoder. This eliminates the optical errors between encoder channels. These artificially generated pulses are much more accurate for dot placement than the encoder quadrature output, which relies on optical and analog measures.

As mentioned in the print mode descriptions, accurate dot placement is crucial when printing bidirectionally. Errors show up as small horizontal offsets (in the range of 0.001 to 0.004 inch) when a line is printed vertically down the page. Because the velocity is well-controlled by means of the encoder, the firmware can repeatedly compensate for the drop trajectory in either scan direction.

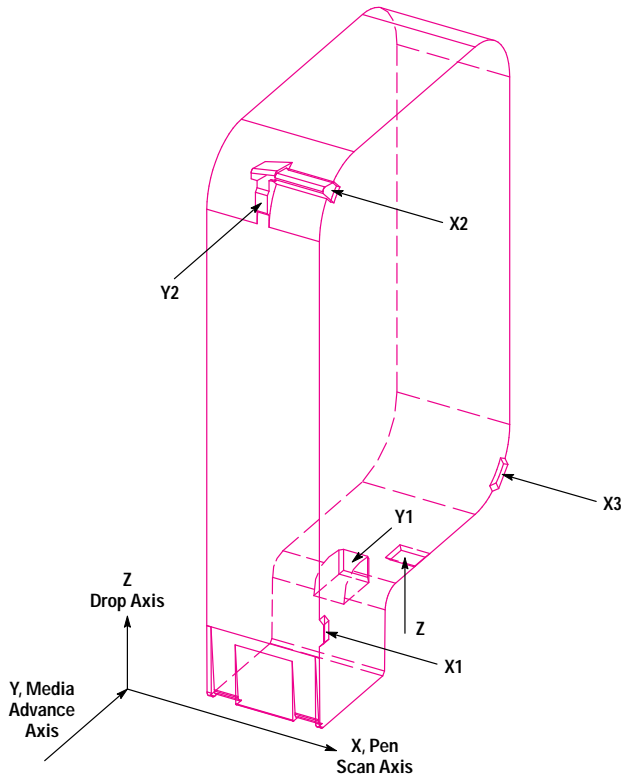

Fig. 4. HP DeskJet 1200C print cartridge datums.

The dynamic rotation about the Z axis (perpendicular to the media) and chatter effects of the carriage in unidirectional and bidirectional printing are minimized through the use of a preloaded bushing and spring that bias the carriage against the slider rod on which the carriage rides.

Print Cartridge Alignment

Another critical factor in attaining high-accuracy dot-to-dot alignment in a four-print-cartridge printer is the alignment between the print cartridges. For practical purposes, the alignment of the print cartridges is defined by three tolerances: the tolerance of positioning the print cartridges in the X or carriage axis and the Y or media axis, and the angular tolerance about the Z axis, which is normal to the media surface (see Fig. 4). The angular tolerance is required to keep vertical lines from having a jagged appearance. These tolerances must be kept as small as possible while taking into consideration the need to keep the carriage and printer small, easy to use, and inexpensive.

Several possible solutions to the problem of attaining accurate print-cartridge-to-print-cartridge alignment were investigated. One idea was to develop a part design and molding process that could hold the required tolerances. This was considered risky, and the mechanical architecture that was developing did not appear to lend itself to this approach. A second concept was to use a test plot and front-panel controls to allow the user to tell the printer how much to move each color plane to achieve good dot-to-dot alignment. This option would have worked well to provide a high-quality printing solution, but it was felt that it required too much customer interaction. Also considered was a mechanical

adjustment of the print cartridge position to attain the desired alignment. This system would allow near perfect alignment, but would tend to be bulky, complex, expensive, and possibly, again require more of the customer than desired.

The selected solution is to machine three of the six points of contact (datums) on both the print cartridge and the carriage. Three of the datums are far away from the printhead (X2, Y2, Z), so their position can vary as much as normal molding tolerances without introducing significant print-cartridge-to-print-cartridge alignment error. The remaining three datums on the print cartridge carriage are located so that they can be easily machined (X1, X3, Y1). The three machined datums are located such that two of them are close to the printhead (X1, Y1) and one is much farther from the printhead (X3). The two datums near the printhead (X1, Y1) control the alignment in the carriage and media axes. The datum farther from the printhead (X3) works with the print cartridge axis datum near the printhead (X1) to control the angle of the printhead such that the column of nozzles on the printhead is parallel to the media advance axis. Biasing springs press the print cartridge against the datums. The combination of the datum locations selected and the machining of the print cartridge and carriage datums provides a simple, inexpensive way of attaining tight alignment tolerances between the print cartridges. The system is open-loop, yet reliable and requires no customer interaction.

Paper Advance

An analysis of the contributions to print quality from various mechanical designs within the printer would be incomplete without an exploration of the paper advance system. This system was given heavy focus throughout the DeskJet 1200C development because advance accuracy is such a large component of dot placement and poor advance accuracy produces the very visible error called banding.

The paper advance mechanism in the DeskJet 1200C consists of a stepper motor, a helical pinion, a helical drive gear, and a drive shaft with two drive wheels to push the media. The system is designed to make 32-nozzle moves for three-pass color graphics printing and 104-nozzle moves for text printing. In three-pass printing, the dot-to-dot error in the paper direction is accumulated during each of three 32-nozzle moves. Therefore, the paper advance error between 32-, 64-, and 96-nozzle advances controls the banding errors associated with paper advance. To minimize the contribution of the 96-nozzle advance error (potentially the greatest because some of the errors tend to be grow linearly with advance distance), the gear train is designed to turn the stepper motor and its pinion through one revolution during a 96-nozzle move. Thus the pinion and stepper errors are virtually zeroed out each rotation. This design reduces the 96-nozzle error to the same value as the 64-nozzle error, which greatly improves print quality.

The DeskJet 1200C paper advance mechanism is not only designed to provide very accurate paper placement, but also to be manufacturable in a high-volume environment. To meet both goals, a mathematical model (Monte Carlo method) of the drive system was developed. The model simulates the movement of all components in the paper drive

system from the stepper motor and its pinion to the drive gear and shaft. The inputs to the model are component tolerances and other environmental variations that affect drive accuracy; the output is paper advance error. After the validity of the mathematical model was confirmed, the proven model demonstrated that as long as the drive components stay within their specified tolerances, the paper advance will be within specifications as well. These components are produced with at least one standard deviation of process margin, so the resulting paper advance also has process margin. This means that the accuracy of most swath advances is better than the goal.

Throughout the development of the DeskJet 1200C, print quality was one of the main outputs of printer testing, not only at ambient, but also at selected extreme environmental conditions. When print modes or mechanical designs needed

to change, other considerations beyond print quality, such as user friendliness and high-volume manufacturing, were factored into the scope of the changes. Compromise was necessary in all decisions, and yet clear understandings of what each print mode was expected to deliver and the magnitude of a design's effect on print quality kept the printer from becoming too "clever" (i.e., complicated) and provided a design that can truly fit into the mainstream office.

Acknowledgments

The authors of this article would like to thank Jason Arbeiter, Erik Blume, Steve Breidenbach, Lance Cleveland, Ray Cundiff, Paul Dillinger, Frank Drogo, Dan Gilbert, Catherine Hunt, Tim McDonough, Jim Ruder and the entire DeskJet 1200C and print cartridge development team for their contributions to this product.