

High-Speed Digital Transmitter Characterization Using Eye Diagram Analysis

The eye diagram analyzer constructs both conventional eye diagrams and special eyeline diagrams to perform extinction ratio and mask tests on digital transmitters. It also makes a number of diagnostic measurements to determine if such factors as waveform distortion, intersymbol interference, or noise are limiting the bit error ratio of a transmission system.

by Christopher M. Miller

The goal of any transmission system is to deliver error-free information reliably and economically from one location to another. The probability that any bit in the data stream is received in error is measured by a bit error ratio (BER) test. This test is performed using an error performance analyzer, commonly referred to as a BER tester or BERT. Generally, a pseudorandom binary sequence (PRBS) from a pattern generator is used to modulate the transmission system's source, while an error detector compares the received signal with the original transmitted pattern. The BER is defined as the number of bits received in error divided by the number of bits transmitted, which equals the error count in a measurement period divided by the product of the bit rate and the measurement period.

In general, BERT measurements tend to be pass/fail in nature, and convey very little information about a failure. Moreover, some additional tests are usually required on components to ensure that they will meet the desired BER when they are installed into a system. For these reasons, it is desirable to perform a number of parametric measurements

on the transmitted waveform in the time domain. Typically, an oscilloscope or an eye diagram analyzer is added to the BERT system as shown in the typical optical transmitter measurement setup in Fig. 1.

The pattern generator is still used to provide the stimulus. Different time-domain displays can be obtained depending on the choice of the trigger signal. When the pattern trigger or frame provides the trigger signal, a stable portion of the pattern appears on the display. When the clock frequency is used as a trigger signal, the data pattern waveform, superimposed on itself, produces a waveform display that is referred to as an eye diagram as shown in Fig. 2a. In general, the more open the eye is, the lower the likelihood that the receiver in a transmission system may mistake a logical 1 bit for a logical 0 bit or vice versa.

In an effort to standardize the high-speed telecommunication systems that are being developed and deployed, standards have been adopted for equipment manufacturers and service providers. Two such standards are the synchronous optical

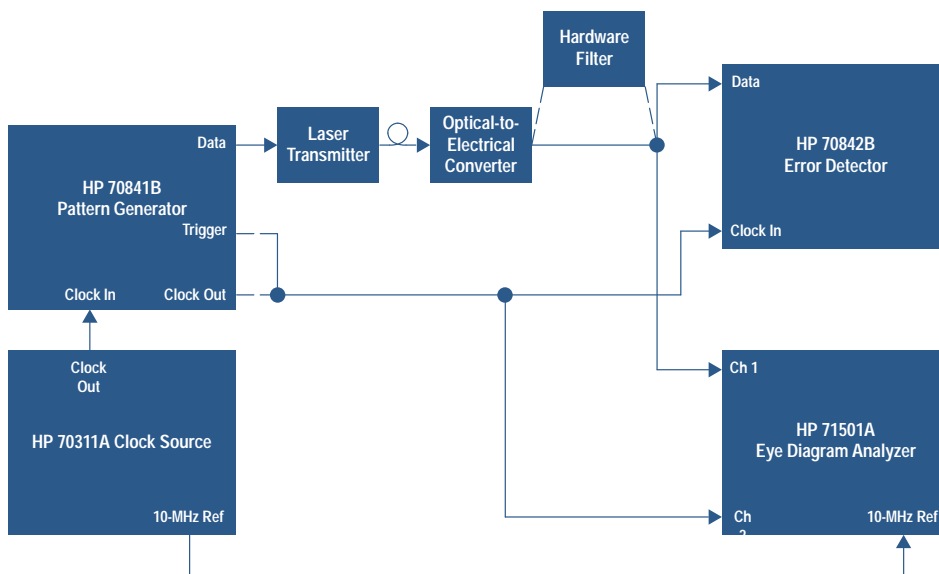
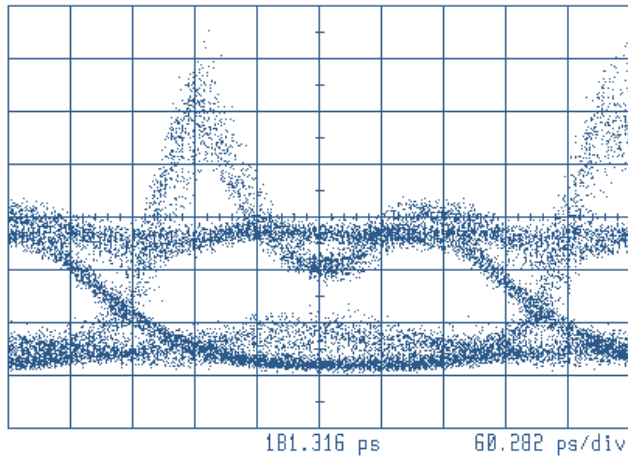
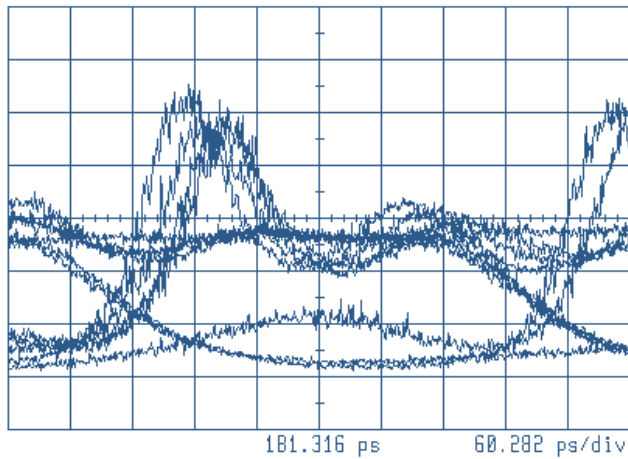

Fig. 1. Digital transmitter parametric test setup using an eye diagram analyzer.



Tr1=Ch1
80 mV/div
240 mV ref

(a)



Tr1=Ch1
80 mV/div
240 mV ref

(b)

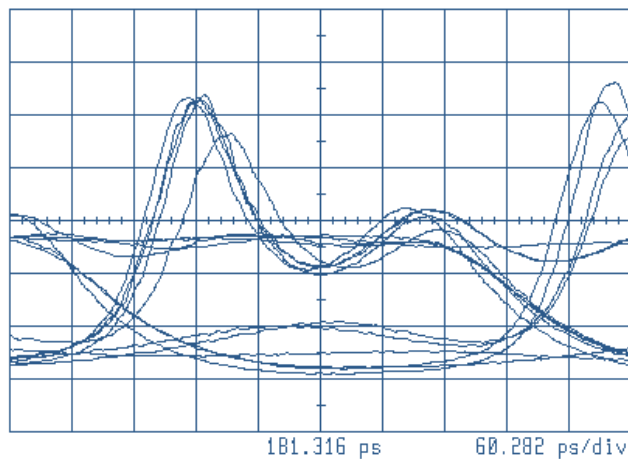

Tr1=Ch1
80 mV/div
240 mV ref

(c)

Fig. 2. (a) Conventional eye diagram. (b) Eyeline diagram. (c) Eyeline diagram with eye filtering.

network (SONET), a North American standard, and the synchronous digital hierarchy (SDH), an international standard. Both standards are for high-capacity fiber-optic transmission and have similar physical layer definitions. These standards define the features and functionality of a transport system based on principles of synchronous multiplexing. The more widely used transmission rates are 155.52 Mbits/s, 622.08 Mbits/s, and 2.48832 Gbits/s.

One of the goals of the standards is to provide “mid-span meet” so that equipment from multiple vendors can be used in the same telecommunications link. The standards specify extinction ratio and eye mask measurements on the transmitted eye diagram to help ensure that transmitters from various vendors are compatible.^{1,2} The eye diagram shown in Fig. 2a is from a laser transmitter operating at 2.48832 Gbits/s. It shows the characteristic laser turn-on overshoot and ringing.

Eye Diagram Characterization

An important specified test parameter for these transmission systems is the extinction ratio (ER) of the eye diagram. It is typically defined as:

$$ER = 10 \log \frac{P_{avg(logic\ 1)}}{P_{avg(logic\ 0)}}$$

where $P_{avg(logic\ 1)}$ is the mean or average optical power level of the logic 1 level and $P_{avg(logic\ 0)}$ is the mean or average optical power level of the logic 0 level. For SONET/SDH transmission systems, the minimum specified extinction ratio is 10 dB. In some cases, the extinction ratio is expressed as the linear ratio of the two power levels. A good extinction ratio is desired in these systems to maintain an adequate received signal-to-noise ratio.

Although the definition of extinction ratio is relatively straightforward, the measurement methodology to determine the mean logic levels is not specified in the standards, such as SDH standard G.957. The histogram and statistical analysis capability of digitizing oscilloscopes can be used to determine the mean and standard deviation (sigma) of a waveform. However, there are no standard criteria for setting the windows and limits for the collection and evaluation of the data to determine the mean logic levels.

The Telecommunications Industry Association/Electronics Industry Association (TIA/EIA) has developed a recommended methodology for making eye diagram measurements called the Optical Fiber Standard Test Procedure #4 (OFSTP-4).³ It recommends that voltage histograms be used to determine the most prevalent logic 1 and 0 levels of the eye pattern measured across an entire bit period. The OFSTP-4 also points out the importance of removing any residual dc offset from the extinction ratio measurement because this can dramatically affect the measurement accuracy.

Over the years, the designers of digital transmission systems have learned that the eye diagram should have a particular shape to achieve a good BER. Often these designers have constructed areas, or masks, inside and around the eye diagram. The eye diagram waveform should not enter into these masked areas. The polygons in the center of the eye diagram shown in Fig. 3 and the lines at the top and bottom correspond to the mask used to evaluate optical transmitters

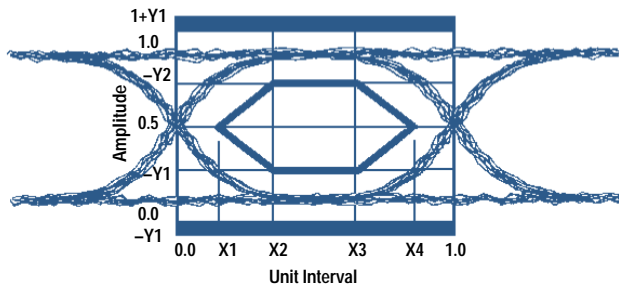

	STM-1 (155.52 Mbits/s)	STM-4 (622.08 Mbits/s)
X1 / X4	0.15 / 0.85	0.25 / 0.75
X2 / X3	0.35 / 0.65	0.40 / 0.60
Y1 / Y2	0.20 / 0.80	0.20 / 0.80

	STM-16 (2.48832 Gbits/s)
X3 - X2	0.20
Y1 / Y2	0.25 / 0.75

Fig. 3. Laser transmitter eye diagram masks for SONET/SDH transmission systems.

intended for use in SONET/SDH systems. Depending on the transmission bit rate, the size and shape of the mask changes. The x and y coordinates are specified for each bit rate and their relative positions are based on the mean logical 1 level and the mean logical 0 level. The mask for the lower bit rates is a hexagon, whereas the mask for 2.48832-Gbit/s transmission is a rectangle. The receiver bandwidth for the measurement of the transmitted eye diagram is specified to be a fourth-order Bessel-Thomson response with a reference frequency at three fourths of the bit rate. This ensures a common reference bandwidth for transmitter evaluation. Hardware low-pass filters are commonly employed to achieve this response.

To date, existing instrumentation has been inadequate to design, build, and test optical transmitters sufficiently to meet the requirements of these transmission standards in certain key areas. Repeatable extinction ratio measurements are often difficult to obtain, particularly extinction ratio measurements of the low-power optical signals common in these systems. Easy-to-use mask compliance testing, with default standard masks that automatically scale to the data would be a convenience. But, most significantly, a tool to aid designers in diagnosing transmitted BER problems would be a major contribution.

Eye Diagram Analyzer

The HP 71501A eye diagram analyzer combines the HP 70820A transition analyzer module,⁴ the HP 70004A color display and mainframe, and the HP 70784A eye diagram personality. The personality is stored on a 128K-byte ROM card and can be downloaded into the instrument. The instrument can be used with a number of optical converters. When the eye diagram analyzer is combined with a pattern generator such as a member of the HP 71600 family of pattern generators, a number of formerly difficult transmission measurements can be made easily. This instrument configuration is shown in Fig. 4.



Fig. 4. Photograph of the HP 71501A eye diagram analyzer with an HP 71603B pattern generator system.

The operation of the HP 71501A differs from that of a conventional digital repetitive sampling oscilloscope. As shown in Fig. 5, both instruments have microwave samplers to sample the incoming waveform before it is digitized by an analog-to-digital converter (ADC). A digitizing oscilloscope has a trigger input that is used to start a sample. In addition, an incremental delay is added to the trigger signal so the samples step through the input waveform. After many cycles of the incoming signal, a complete trace of the input waveform is constructed.

The sample rate of the eye diagram analyzer is not determined by an external trigger, but it is set according to the frequency content of the incoming signal itself. As the incoming signal is digitized, it is analyzed to determine an appropriate sample frequency to down-convert it optimally into the intermediate frequency (IF) section.

As shown in the block diagram, Fig. 6, the HP 71501A has two identical signal processing channels which can sample and digitize signals from dc up to 40 GHz. Input signals to each channel are sampled by a microwave sampler at a rate (f_s) between 10 MHz and 20 MHz. The sample rate is dependent upon the signal frequency and the type of measurement being made. The outputs of the samplers are fed into the dc-to-10-MHz IF sections. The IF sections contain switchable low-pass filters and step-gain amplifiers. The dc components of the measured signal are tapped off ahead of the microwave sampler and summed into the IF signal separately. The outputs of the IF sections are sampled at the same rate as the input signal and then converted to a digital signal by the ADCs.

Once the signals are digitized, they are fed into the buffer memories. These buffers hold the samples until the trigger point is determined. The buffer memories make it possible to view signals before the trigger event without using delay

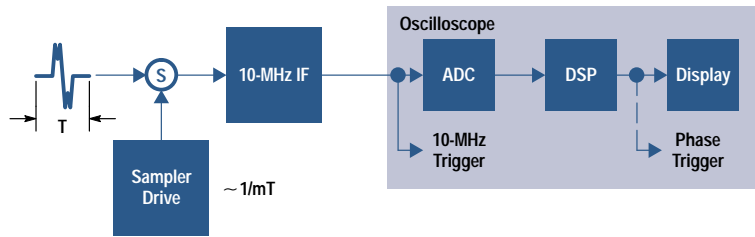

Fig. 5. Simplified architectural comparison of the eye diagram analyzer (a) and a conventional sampling oscilloscope (b).

lines. By triggering on the IF signal, the HP 71501A is able to trigger internally on signals with fundamental frequencies as high as 40 GHz. Once the trigger point has been determined and all the necessary data has been acquired, the appropriate data is sent to the digital signal processing (DSP) chips.

An FFT is performed on the time data that is sent to the DSP chips. With the time data now converted into the frequency domain, IF corrections are applied to the data. The IF corrections compensate for nonidealities in the analog signal processing path. In addition, in certain modes of operation, the nominal measurement 3-dB bandwidth of 22 GHz can be extended to 40 GHz by applying RF corrections. The RF corrections compensate for microwave sampler conversion efficiency roll-off versus frequency. Similarly, in these modes of operation, user-entered corrections or filtering can be applied at this point as frequency-domain multiplication. As we will see later, this is a very useful capability. Finally, the inverse FFT is performed.

Generating Eye and Eyeline Diagrams

Fig. 7 shows how the HP 71501A acquires data in the time domain using a technique called harmonic repetitive sampling. The sample rate is set so that successive sample points step through the measured waveform with a specified time step. The sampling period, T_s , is computed using the fundamental signal period, the time span, and the number of trace points. T_s is set such that an integer number (N) of signal periods plus a small time increment (ΔT) occur between successive sample points. For example, suppose that the input signal is a 100-MHz square wave as shown in Fig. 7. The minimum sampling period of the HP 71501A is 50 ns. Therefore, five cycles of the input waveform are skipped between samples. However, if the sample period were set to exactly 50 ns, sampling would occur at the same point on every fifth cycle, and no new information would be gained. For a time span of 10 ns and the number of trace points

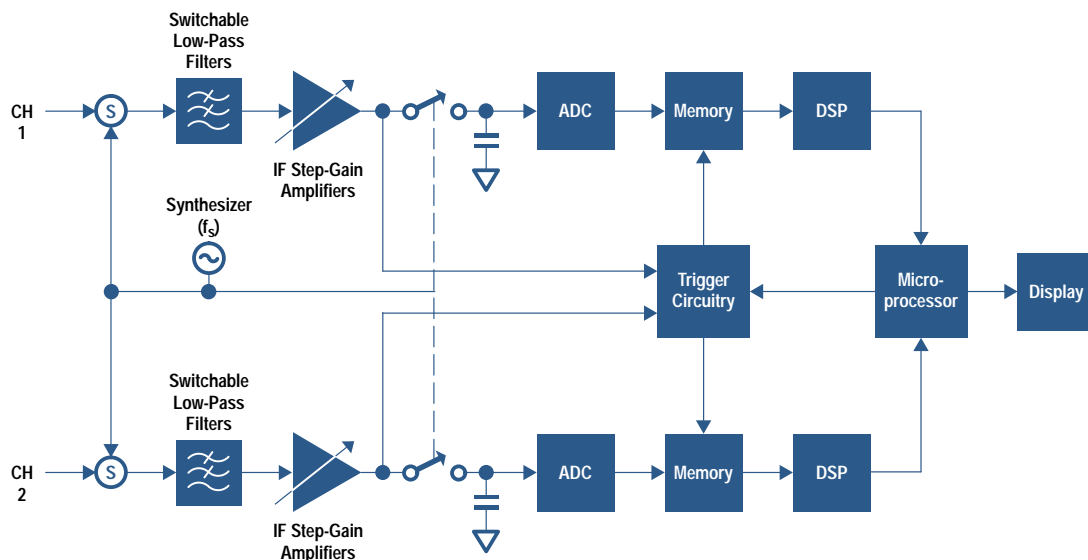
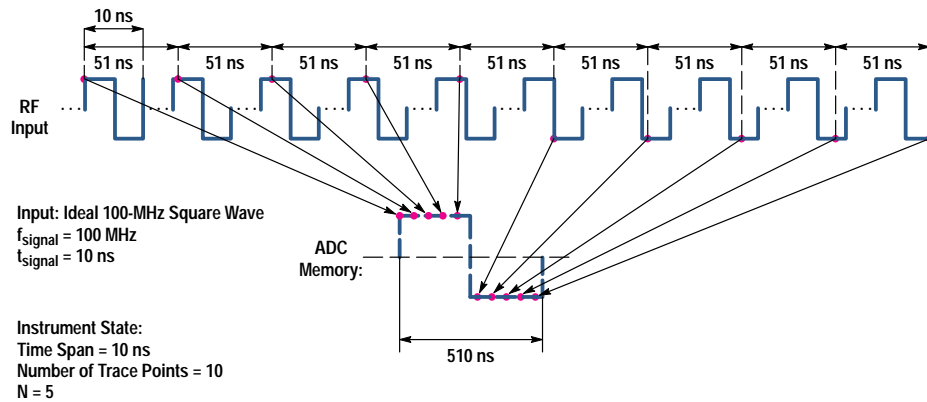

Fig. 6. Simplified block diagram of the eye diagram analyzer.



$$T_s = \frac{1}{f_s} = (N \times T_{\text{signal}}) + \Delta T$$

$$\Delta T = \frac{\text{Time Span}}{\text{Number of Trace Points}} = \frac{10 \text{ ns}}{10} = 1 \text{ ns}$$

Therefore: $T_s = 51 \text{ ns}$

Fig. 7. Harmonic repetitive sampling of a waveform.

equal to 10 points, a time resolution or ΔT of 1 ns is required. For this time resolution, the actual sample period is $50 \text{ ns} + 1 \text{ ns} = 51 \text{ ns}$. Thus, at every fifth cycle of the input waveform the sampling point moves forward 1 ns, and after fifty cycles of the input waveform, one complete trace of the input signal would be displayed.

With the signal frequency set equal to the clock frequency, the HP 71501A uses the process of harmonic repetitive sampling to generate eye diagrams similar in appearance to those of sampling oscilloscopes. The eye diagram of a pseudorandom bit sequence (PRBS) obtained in this manner is shown in Fig. 2a. Like the display of a conventional digital sampling oscilloscope, the eye diagram is constructed from samples of a number of bits in the sequence, which are displayed as a family of dots when persistence mode is activated. The only relationship between the samples or dots is their position relative to a trigger point, which is usually the rising or falling edge of a clock signal.

The HP 71501A uses a modified version of this same technique of repetitive sampling to construct the *eyeline diagrams* of PRBS signals or any bit sequence whose pattern repeats. Fig. 2b shows an eyeline diagram of the same laser

transmitter as Fig. 2a. In this mode, successive samples come from the same or adjacent bits in the pattern. The samples or dots in these eyeline diagrams can be connected, and a whole trace or portion of the bit sequence is displayed at one time. When the display is in persistence mode, a number of traces of different portions of the bit sequence are superimposed, forming the eyeline diagram. The continuous traces that make up the eyeline diagram convey much more information than the sampled smear of dots observed in the conventional eye diagram. The pattern dependent traces that make up the eyeline diagram, as well as the bit transitions, are readily seen. With the eyeline display it is possible to observe whether noise, intersymbol interference, or mismatch ripple is causing eye closure.

When the HP 71501A is placed in the eyeline mode, f_{signal} is set to the clock rate divided by the pattern length, and T_s is set such that successive sample points step through the waveform pattern. ΔT is computed exactly as before. For the example shown in Fig. 8, the clock frequency is 1 GHz, the pattern length is 15 bits, and f_{signal} is 66.67 MHz. For a time span of 15 ns and the number of trace points equal to 15, a ΔT of 1 ns is required. T_s can be computed to be 61 ns.

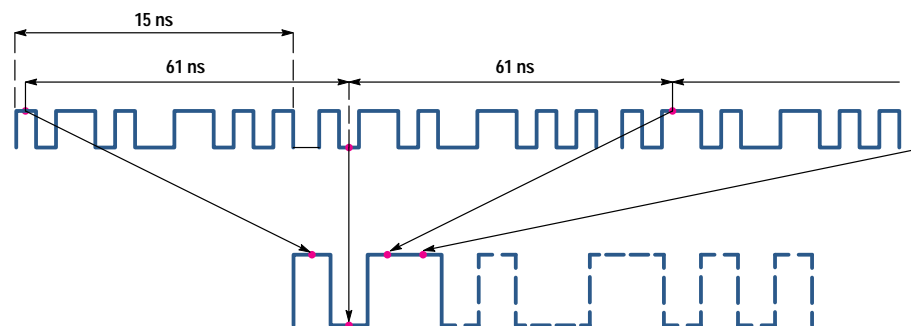

Input: 1-Gbit/s, 15-Bit Pattern
 $f_{\text{clock}} = 1 \text{ GHz}$
 Pattern Length = 15 bits
 $f_{\text{signal}} = 66.67 \text{ MHz}$
 $T_{\text{signal}} = 15 \text{ ns}$

Instrument State:
 Time Span = 15 ns
 Trace Length = 15
 N = 4

$$T_s = \frac{1}{f_s} = (N \times T_{\text{signal}}) + \Delta T$$

$$\Delta T = \frac{\text{Time Span}}{\text{Trace Length}} = \frac{15 \text{ ns}}{15} = 1 \text{ ns}$$

Therefore: $T_s = 61 \text{ ns}$

Fig. 8. Harmonic repetitive sampling of a PRBS waveform to generate an eyeline diagram.

Thus, every fourth cycle of the pattern, the sampling point moves forward 1 ns, and after sixty cycles of the pattern waveform, one complete trace of the pattern is displayed.

Eye Filtering

The eyeline mode traces can be filtered to remove the noise and nonpattern dependent effects. As shown in Fig. 2c, this allows an enormous improvement in the ability to view the individual traces. The reduction in trace noise and the improvement in signal-to-noise ratio (SNR) available in eyeline mode are enabled by turning on the eye filter. Trace averaging, a common technique to improve the SNR of time-domain displays of a stable pattern, cannot be applied to conventional eye diagrams because the averaged waveform would converge to the dc or average level.

For signals with pattern repetition frequencies greater than 10 MHz, turning on the eye filter switches in a 100-kHz IF hardware filter. This effectively reduces the IF bandwidth from 10 MHz to 100 kHz, which provides a fixed 20-dB signal-to-noise improvement. However, for most PRBS signals, the pattern repetition frequency is much less than 10 MHz. In this case, additional digital signal processing is performed to improve the SNR. In essence, a number of samples are taken at each time record point in the measured waveform. This is accomplished by sampling at a rate equal to or harmonically related to the pattern repetition frequency. For each time point, the samples are passed through a narrow-band filter implemented with an FFT. To sample the next trace point, the internal synthesizer controlling the sampling rate is phase-shifted a precise amount. This process is repeated for each trace point. The actual amount of noise reduction or processing gain is a function of the number of samples taken at each trace point. From an operational standpoint, the amount of processing gain is represented by an equivalent noise-filter bandwidth. The bandwidth of the filter indicates the relative noise reduction normalized to the 10-MHz IF bandwidth. As the effective bandwidth is reduced, the number of samples increases, and the trace update rate gets slower. The following table shows the SNR ratio improvement for a given number of samples.

Equivalent Filter Bandwidth	SNR Improvement	Number of Samples
10 MHz	0 dB	1
2 MHz	7 dB	16
1 MHz	10 dB	32
500 kHz	13 dB	64
250 kHz	16 dB	128
125 kHz	19 dB	256
62.5 kHz	22 dB	512

The eyeline mode with eye filtering offers a significant improvement over conventional eye diagram measurements in the ability to observe low optical signal levels. Shown in Fig. 9a is the same laser transmitter whose output now has been optically attenuated. This conventional eye diagram display is of poor quality because of inherent sensitivity limitations and the inability to perform trace averaging on a PRBS waveform. Enabling the eyeline mode and activating the eye filter makes the eye diagram once again clearly visible as shown in Fig. 9b. This function makes it easy to observe signals that are only several millivolts in amplitude, which is impossible

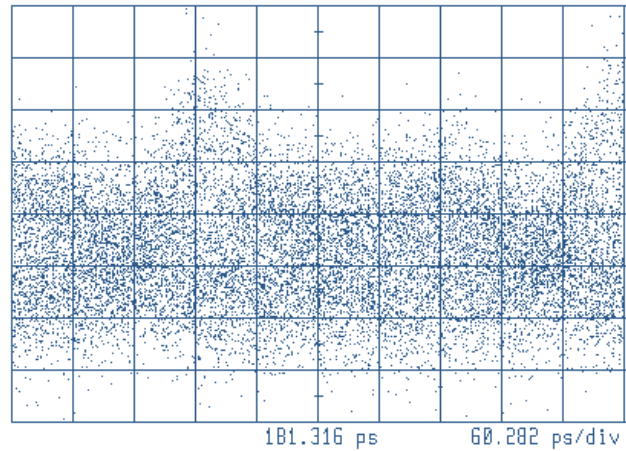

Tr1=Ch1
2 mV/div
4 mV ref

(a)

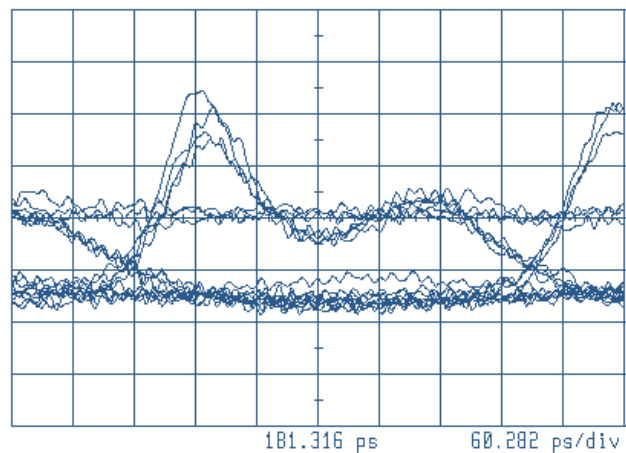

Tr1=Ch1
2 mV/div
4 mV ref

(b)

Fig. 9. (a) Conventional eye diagram of a low-level signal. (b) Eyeline diagram of a low-level signal with eye filtering applied.

to do with conventional high-speed digital sampling oscilloscopes.

An application of this measurement capability is the observation of the eye diagram of a transmitted optical signal after the signal has passed through a long length of optical fiber. Because of the attenuation of the fiber, eye diagrams are often difficult to observe in this manner. With the eyeline mode, it is possible to determine if the chirp of the laser transmitter, along with the dispersion in the fiber, is causing any waveform distortion.

Software Corrections and Filtering

RF corrections can be applied to extend the measurement bandwidth of the HP 71501A to 40 GHz while the instrument is in the eyeline display mode, in which a unique mapping exists between the IF frequency and the input RF frequency. When the IF signal is digitized, an FFT is used to convert it to the frequency domain. The IF frequencies are then mapped into the corresponding RF frequencies, and the

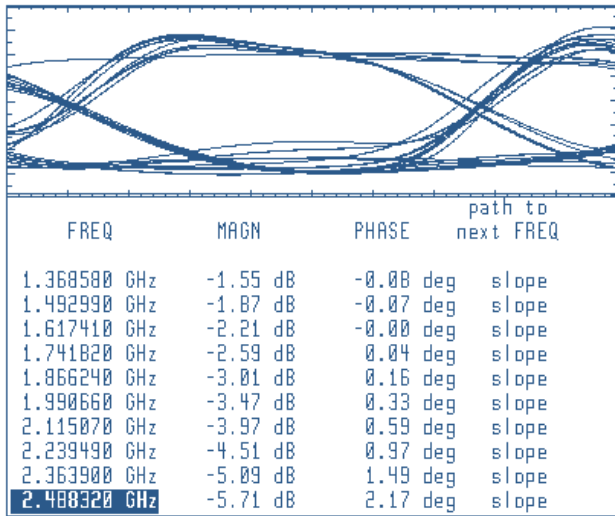

Fig. 10. Eye diagram with software filtering applied and user correction table corresponding to a fourth-order Bessel-Thomson response.

appropriate correction is applied at each frequency. Finally, an inverse FFT is applied to the result to transform it back to the time domain. These same processing routines are available for user-defined corrections or filters. For example, this capability can be used to calibrate the eyeline lightwave measurements by correcting for any optical converter roll-off. In addition, it can be used to evaluate eyeline diagrams under different filter response conditions.

As previously mentioned, the transmission standards require that the eye mask measurements be made in a receiver bandwidth that corresponds to a fourth-order Bessel-Thomson response with a reference frequency at three fourths of the bit rate. Hardware filters or special lightwave converters are often employed to achieve this. By using the user corrections available in the HP 71501A, the ideal transfer function can be implemented with a software filter. The filtered display shown in Fig. 10 was made with a software filter applied that corresponded to the desired ideal Bessel-Thomson response.

Up to 128 magnitude and phase points can be loaded as user corrections. Shown in the lower half of Fig. 10 is a portion of the user correction table that corresponds to the fourth-order Bessel-Thomson response. This table of magnitude and phase corrections was generated directly from trace math functions that are available in the HP 71501A. The linear portion of the phase has been corrected to remove the delay. This allows the trace to remain in the same place when the corrections are applied. Software filters for the major SONET/SDH transmission rates are stored on the ROM memory card. This capability could also be used to develop an equalizer or tailor a specific response to improve the received eye diagram. Thus, the transmitted "equalized" eye diagram could be simulated and observed before the final hardware equalization filter is constructed.

User Interface

An application-specific user interface was designed for the eye diagram analyzer. The goals of the user interface were to offer turnkey measurements that meet the requirements of the standards, to be easy to use, and to make the interface to the pattern generator as transparent as possible. Many of the specific measurements will be described in the next sections. One ease-of-use feature is the ability to set the time base in bit unit intervals, instead of having to recall the clock period to display the eye diagram. Time delay can also be set in bit intervals, which makes it convenient to scroll through the bits that make up the pattern. A menu key, READ PAT GEN, is used to interrogate the pattern generator. It returns the clock frequency, the pattern length, and the data, clock, and trigger levels, which are used to set up the display.

The eye diagram application program is written in HP Instrument BASIC and is downloaded into the host instrument, the HP 70820A microwave transition analyzer module. The microwave transition analyzer is an extremely flexible, general-purpose instrument that offers both time-domain and frequency-domain signal analysis capability.⁴ This versatile measurement capability is available simultaneously with the eye diagram measurement capability, and is simply accessed through its own menu.

Eye Diagram Measurements

A number of parametric measurements are often performed on eye diagrams to determine their quality. Some of the more prevalent measurements include eye opening height, eye opening width, amplitude of the crossing level, jitter at the transition point, and the rise and fall times of the bit transitions. Fig. 11 shows a number of these measurements made with the HP 71501A eye diagram analyzer on a laser transmitter operating at 622.08 Mbits/s. The extinction ratio was determined by taking a vertical histogram of the eye diagram windowed over one bit interval. An algorithm that recursively adjusts the limits for subsequent evaluations of the histogram data converges on the most prevalent logical

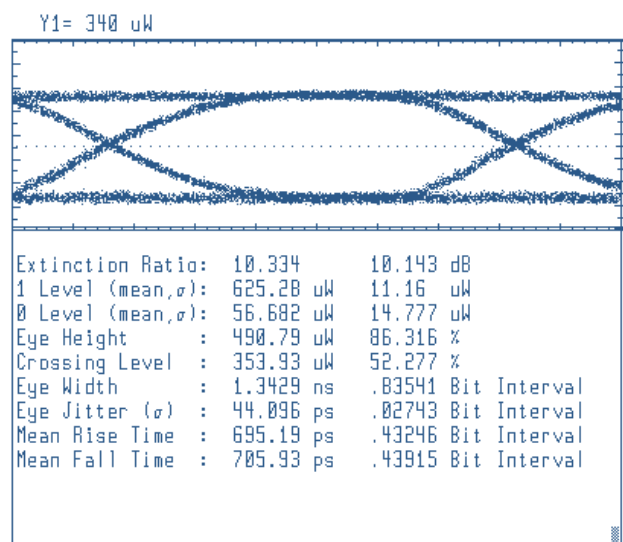

Fig. 11. Table of eye diagram parametric measurements.

1 and 0 levels. The peaks of the histogram are used to set initial limits for the computation of the 1 and 0 levels. The initial mean and standard deviation (sigma) of the 1 level are based on histogram data above the relative 50% point of the peaks. The limits for the next evaluation of the histogram data are set to the initial mean level plus or minus one sigma. The new mean and sigma for the 1 level are then determined. This process iterates several times until the sigma becomes small and the mean converges on the most prevalent 1 level. The determination of the most prevalent 0 level is based on the same algorithm, except that the initial mean and sigma of the 0 level are based on histogram data below the relative 50% point of the peaks. This algorithm for determining extinction ratio has been demonstrated to be more repeatable than merely taking the peaks of the histogram distributions. The other eye parameter measurements are also based on histograms.

At times, it is convenient to display the trace in optical power units. This can be easily done with the HP 71501A. With the responsivity of the optical converter entered as in Fig. 11, we can easily see using the marker functions that the laser is putting out about 340 μ W of average optical power. With the responsivity entered, the eye measurements are displayed in the appropriate optical power units.

To get a good extinction ratio measurement result, it is especially important to get an accurate determination of the average power corresponding to the low logic level. It can be readily shown that a measurement error of a given magnitude has a much greater impact on the value of the low level than the high level. Because of sensitivity limitations, accurate measurement of the low level may be difficult. However, this is an area where the eye filtering capability of the HP 71501A can make a contribution. When making measurements on high-speed laser transmitters with unamplified photodiode converters, the resulting detected voltages are only millivolts in amplitude, making conventional extinction ratio measurements next to impossible. Yet, with the eye filter enabled on the HP 71501A, the extinction ratio can be readily determined.

Mask Measurements

The HP 71501A has a general-purpose mask testing capability with internally stored default masks for the major SONET/SDH transmission rates to test compliance with these standards. These default masks can be autoscaled to the data according to the specifications in the SONET/SDH standard. Mask margin testing is also provided. Fig. 12 shows a SONET/SDH eye diagram mask test performed by the HP 71501A. Once again, the transmission rate was 622.08 Mb/s. The measurement bandwidth was fixed by a hardware filter with a fourth-order Bessel-Thomson response and a reference frequency of 466.56 MHz. For this transmission rate, the default mask consists of a hexagon, M1, in the center of the eye, and upper and lower limit lines, L2 and L3. The default mask has been autoscaled to the data. The error count for each of the mask regions is displayed on the lower portion of the screen, along with a number corresponding to the total traces evaluated. The transmitter measurement shown passes the mask test without any violations. In some instances, it is useful to determine by how much margin a transmitter passes the mask test. It is often desirable in production testing to

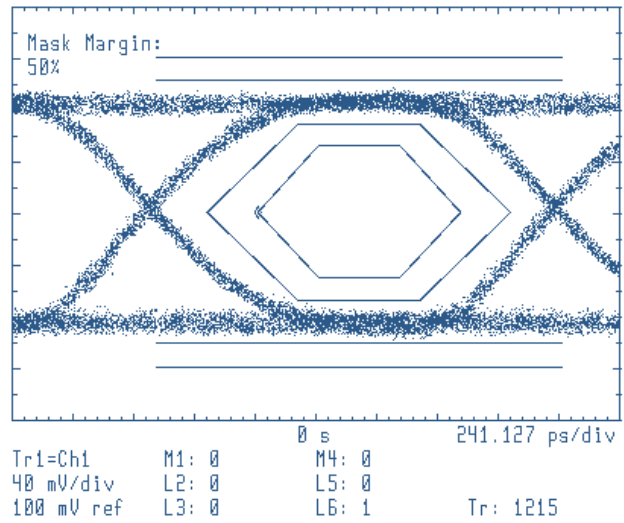

Fig. 12. Eye mask measurement.

allow some additional guardband to ensure that the transmitter can pass the standard mask. M4, L5, and L6 denote the margin mask regions, and one can test for errors simultaneously in those regions as well as the standard mask regions. As shown, there was a margin mask violation of the lower limit after 1215 traces had been evaluated. Custom masks can also be easily constructed for other transmission systems or to assist in the design and troubleshooting of laser transmitters.

Error Trace Capture

The jitter in the data transitions is a very important transmission parameter that has a direct impact on the BER. In many systems only the random jitter is specified. But in optical systems, a deterministic component of jitter that is dependent on the optical pattern is often present. Using the eye-line mode with eye filtering one can observe the peak-to-peak variations in the crossing points as shown in Fig. 13.

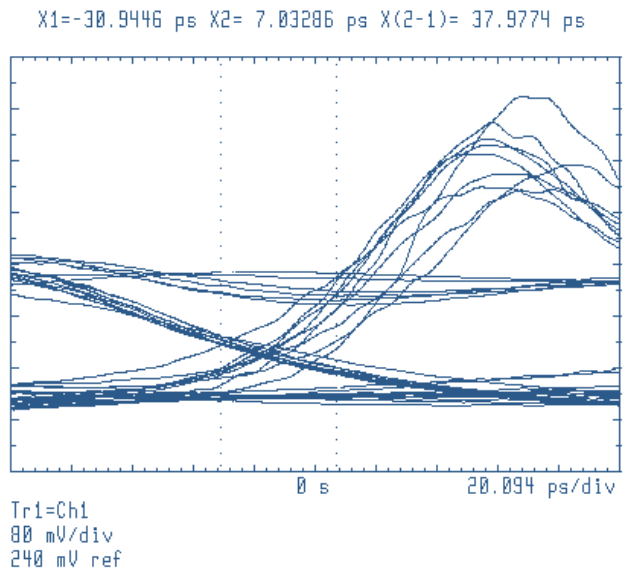

Fig. 13. Jitter in data transitions.

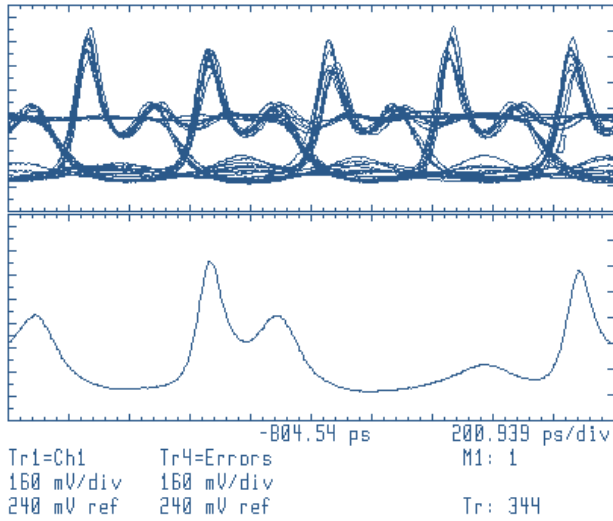

Fig. 14. Error capture of a jittered transition.

To determine if a particular pattern is responsible for the jittered transition, a custom mask can be employed. By displaying several preceding bit intervals and enabling the error trace capture capability of the HP 71501A, one can observe in the lower trace of Fig. 14 that the delayed transition seems to be caused by intersymbol interference from a preceding 100 pattern. The error trace capture is a unique feature of the eye diagram analyzer, made possible by the eye-line display mode and a triggering architecture that allows data before the trigger point to be viewed.

The error trace capture can be applied to a number of measurements. It can be used to observe the pattern leading up to a standard default mask violation. Displayed in Fig. 15 are a transmitter waveform and the associated mask for the 2.48832-Gbit/s transmission rate displayed in the appropriate bandwidth. The error trace here also seems to be a result of intersymbol interference.

Summary

High-speed telecommunication standards require that eye diagram measurements be made on digital transmitters. The HP 71501A eye diagram analyzer is designed to meet these measurement needs by performing industry-standard mask and extinction ratio measurements. It can construct both conventional eye diagrams and unique eyeline diagrams, which can be used for bit error analysis.

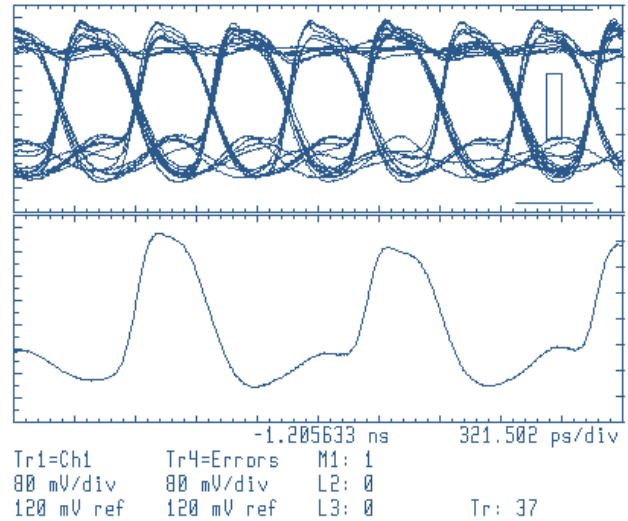

Fig. 15. Error capture of a mask violation.

Acknowledgments

The eye diagram analyzer involved the contributions of a number of people. Chris "CJ" Johansson wrote the IBASIC application program. Steve Peterson was primarily responsible for revisions and upgrades to the host instrument firmware. Steve, along with John Wendler and David Sharrit, provided technical input. John Wilson provided market research and many of the ideas that make up the operation of the application. Finally, Mike Dethlefsen and Mark Slovick modified the existing base instrument's alignment and calibration routines to achieve the eye diagram analyzer's current state-of-the-art time-domain measurement performance.

References

1. *American National Standard for Telecommunication - Digital Hierarchy Optical Interface Specifications, Single Mode*, ANSI T1-106-1988.
2. *Optical Interfaces for Equipments and Systems Relating to the Synchronous Digital Hierarchy*, CCITT Recommendation G.957, 1990.
3. *OFSTP-4 Optical Eye Pattern Measurement Procedure*, TIA/EIA-526-4, 1993.
4. D.J. Ballo and J.A. Wendler, "The Microwave Transition Analyzer: A New Instrument Architecture for Component and Signal Analysis," *Hewlett-Packard Journal*, Vol. 43, no. 5, October 1992, pp. 48-62.